

a-Si TFT LCD Single Chip Driver 240RGBx320 Resolution and 262K color

Datasheet ***Preliminary***

Version: V0.33
Document No.: ILI9325DS_V0.33.pdf

ILI TECHNOLOGY CORP.

4F, No. 2, Tech. 5th Rd., Hsinchu Science Park,
Taiwan 300, R.O.C.
Tel.886-3-5670095; Fax.886-3-5670096
<http://www.ilitek.com>

Table of Contents

Section	Page
1. Introduction.....	7
2. Features	7
3. Block Diagram.....	9
4. Pin Descriptions	10
5. Pad Arrangement and Coordination.....	14
6. Block Description	21
7. System Interface	24
7.1. Interface Specifications	24
7.2. Input Interfaces	25
7.2.1. i80/18-bit System Interface.....	26
7.2.2. i80/16-bit System Interface.....	27
7.2.3. i80/9-bit System Interface.....	28
7.2.4. i80/8-bit System Interface.....	28
7.3. Serial Peripheral Interface (SPI)	29
7.4. VSYNC Interface.....	34
7.5. RGB Input Interface	38
7.5.1. RGB Interface.....	39
7.5.2. RGB Interface Timing	40
7.5.3. Moving Picture Mode.....	42
7.5.4. 6-bit RGB Interface.....	43
7.5.5. 16-bit RGB Interface.....	44
7.5.6. 18-bit RGB Interface.....	44
7.6. Interface Timing.....	47
8. Register Descriptions	48
8.1. Registers Access.....	48
8.2. Instruction Descriptions.....	51
8.2.1. Index (IR).....	53
8.2.2. Start Oscillation (R00h).....	53
8.2.3. Driver Output Control (R01h)	53
8.2.4. LCD Driving Wave Control (R02h)	55
8.2.5. Entry Mode (R03h).....	55
8.2.6. Resizing Control Register (R04h).....	58
8.2.7. Display Control 1 (R07h)	59
8.2.8. Display Control 2 (R08h)	60
8.2.9. Display Control 3 (R09h)	61
8.2.10. Display Control 4 (R0Ah).....	62
8.2.11. RGB Display Interface Control 1 (R0Ch).....	63

8.2.12. Frame Marker Position (R0Dh)	64
8.2.13. RGB Display Interface Control 2 (R0Fh)	64
8.2.14. Power Control 1 (R10h).....	65
8.2.15. Power Control 2 (R11h).....	66
8.2.16. Power Control 3 (R12h).....	67
8.2.17. Power Control 4 (R13h).....	67
8.2.18. GRAM Horizontal/Vertical Address Set (R20h, R21h)	68
8.2.19. Write Data to GRAM (R22h).....	68
8.2.20. Read Data from GRAM (R22h)	69
8.2.21. Power Control 7 (R29h).....	70
8.2.22. Frame Rate and Color Control (R2Bh).....	71
8.2.23. Gamma Control (R30h ~ R3Dh).....	72
8.2.24. Horizontal and Vertical RAM Address Position (R50h, R51h, R52h, R53h)	72
8.2.25. Gate Scan Control (R60h, R61h, R6Ah)	73
8.2.26. Partial Image 1 Display Position (R80h).....	76
8.2.27. Partial Image 1 RAM Start/End Address (R81h, R82h).....	76
8.2.28. Partial Image 2 Display Position (R83h).....	76
8.2.29. Partial Image 2 RAM Start/End Address (R84h, R85h).....	76
8.2.30. Panel Interface Control 1 (R90h).....	77
8.2.31. Panel Interface Control 2 (R92h).....	77
8.2.32. Panel Interface Control 4 (R95h).....	77
8.2.33. OTP VCM Programming Control (RA1h)	78
8.2.34. OTP VCM Status and Enable (RA2h)	78
8.2.35. OTP Programming ID Key (RA5h)	79
9. OTP Programming Flow.....	80
10. GRAM Address Map & Read/Write	83
11. Window Address Function.....	89
12. Gamma Correction	91
13. Application.....	96
13.1. Configuration of Power Supply Circuit	96
13.2. Display ON/OFF Sequence	98
13.3. Standby and Sleep Mode	99
13.4. Power Supply Configuration	100
13.5. Voltage Generation	101
13.6. Applied Voltage to the TFT panel.....	102
13.7. Partial Display Function	102
13.8. Resizing Function.....	103
14. Electrical Characteristics.....	106
14.1. Absolute Maximum Ratings	106

14.2. DC Characteristics	107
14.3. Reset Timing Characteristics	107
14.4. AC Characteristics	107
14.4.1. i80-System Interface Timing Characteristics	107
14.4.2. Serial Data Transfer Interface Timing Characteristics	108
14.4.3. RGB Interface Timing Characteristics	109
15. Revision History	111

Figures

FIGURE1 SYSTEM INTERFACE AND RGB INTERFACE CONNECTION 25

FIGURE2 18-BIT SYSTEM INTERFACE DATA FORMAT 26

FIGURE3 16-BIT SYSTEM INTERFACE DATA FORMAT 27

FIGURE4 9-BIT SYSTEM INTERFACE DATA FORMAT 28

FIGURE5 8-BIT SYSTEM INTERFACE DATA FORMAT 29

FIGURE6 DATA TRANSFER SYNCHRONIZATION IN 8/9-BIT SYSTEM INTERFACE..... 29

FIGURE 7 DATA FORMAT OF SPI INTERFACE..... 31

FIGURE8 DATA TRANSMISSION THROUGH SERIAL PERIPHERAL INTERFACE (SPI) 32

FIGURE9 DATA TRANSMISSION THROUGH SERIAL PERIPHERAL INTERFACE (SPI), TRI="1" AND DFM="10")..... 33

FIGURE10 DATA TRANSMISSION THROUGH VSYNC INTERFACE)..... 34

FIGURE11 MOVING PICTURE DATA TRANSMISSION THROUGH VSYNC INTERFACE 34

FIGURE12 OPERATION THROUGH VSYNC INTERFACE 35

FIGURE13 TRANSITION FLOW BETWEEN VSYNC AND INTERNAL CLOCK OPERATION MODES 37

FIGURE14 RGB INTERFACE DATA FORMAT 38

FIGURE15 GRAM ACCESS AREA BY RGB INTERFACE 39

FIGURE16 TIMING CHART OF SIGNALS IN 18-/16-BIT RGB INTERFACE MODE..... 40

FIGURE17 TIMING CHART OF SIGNALS IN 6-BIT RGB INTERFACE MODE 41

FIGURE18 EXAMPLE OF UPDATE THE STILL AND MOVING PICTURE..... 42

FIGURE19 INTERNAL CLOCK OPERATION/RGB INTERFACE MODE SWITCHING 45

FIGURE20 GRAM ACCESS BETWEEN SYSTEM INTERFACE AND RGB INTERFACE 46

FIGURE21 RELATIONSHIP BETWEEN RGB I/F SIGNALS AND LCD DRIVING SIGNALS FOR PANEL 47

FIGURE22 REGISTER SETTING WITH SERIAL PERIPHERAL INTERFACE (SPI)..... 48

FIGURE23 REGISTER SETTING WITH I80 SYSTEM INTERFACE 49

FIGURE 24 REGISTER READ/WRITE TIMING OF I80 SYSTEM INTERFACE 50

FIGURE25 GRAM ACCESS DIRECTION SETTING 56

FIGURE26 GRAM HIGH-SPEED WRITE MODE..... 57

FIGURE27 HIGH-SPEED CONSECUTIVE WRITE OPERATION (IN 18/16-BIT INTERFACE MODE)..... 57

FIGURE28 16-BIT MPU SYSTEM INTERFACE DATA FORMAT..... 58

FIGURE29 8-BIT MPU SYSTEM INTERFACE DATA FORMAT..... 58

FIGURE 30 DATA READ FROM GRAM THROUGH READ DATA REGISTER IN 18-/16-/9-/8-BIT INTERFACE MODE..... 69

FIGURE 31 GRAM DATA READ BACK FLOW CHART 70

FIGURE 32 GRAM ACCESS RANGE CONFIGURATION 73

FIGURE33 GRAM READ/WRITE TIMING OF I80-SYSTEM INTERFACE 83

FIGURE34 I80-SYSTEM INTERFACE WITH 18-/16-/9-BIT DATA BUS (SS="0", BGR="0") 85

FIGURE35 I80-SYSTEM INTERFACE WITH 8-BIT DATA BUS (SS="0", BGR="0") 86

FIGURE 36 I80-SYSTEM INTERFACE WITH 18-/9-BIT DATA BUS (SS="1", BGR="1") 88

FIGURE 37 GRAM ACCESS WINDOW MAP 89

FIGURE 38 GRAYSCALE VOLTAGE GENERATION..... 91

FIGURE 39 GRAYSCALE VOLTAGE ADJUSTMENT	92
FIGURE 40 GAMMA CURVE ADJUSTMENT	93
FIGURE 41 RELATIONSHIP BETWEEN SOURCE OUTPUT AND VCOM	95
FIGURE 42 RELATIONSHIP BETWEEN GRAM DATA AND OUTPUT LEVEL.....	95
FIGURE 43 POWER SUPPLY CIRCUIT BLOCK.....	96
FIGURE 44 DISPLAY ON/OFF REGISTER SETTING SEQUENCE	98
FIGURE 45 STANDBY/SLEEP MODE REGISTER SETTING SEQUENCE.....	99
FIGURE 46 POWER SUPPLY ON/OFF SEQUENCE	100
FIGURE 47 VOLTAGE CONFIGURATION DIAGRAM	101
FIGURE 48 VOLTAGE OUTPUT TO TFT LCD PANEL	102
FIGURE 49 PARTIAL DISPLAY EXAMPLE.....	103
FIGURE 50 DATA TRANSFER IN RESIZING	104
FIGURE 51 RESIZING EXAMPLE	104
FIGURE 52 I80-SYSTEM BUS TIMING	108
FIGURE 53 SPI SYSTEM BUS TIMING	109
FIGURE54 RGB INTERFACE TIMING	110

1. Introduction

ILI9325 is a 262,144-color one-chip SoC driver for a-TFT liquid crystal display with resolution of 240RGBx320 dots, comprising a 720-channel source driver, a 320-channel gate driver, 172,800 bytes RAM for graphic data of 240RGBx320 dots, and power supply circuit.

ILI9325 has four kinds of system interfaces which are i80-system MPU interface (8-/9-/16-/18-bit bus width), VSYNC interface (system interface + VSYNC, internal clock, DB[17:0]), serial data transfer interface (SPI) and RGB 6-/16-/18-bit interface (DOTCLK, VSYNC, HSYNC, ENABLE, DB[17:0]).

In RGB interface and VSYNC interface mode, the combined use of high-speed RAM write function and widow address function enables to display a moving picture at a position specified by a user and still pictures in other areas on the screen simultaneously, which makes it possible to transfer display the refresh data only to minimize data transfers and power consumption.

ILI9325 can operate with 1.65V I/O interface voltage, and an incorporated voltage follower circuit to generate voltage levels for driving an LCD. The ILI9325 also supports a function to display in 8 colors and a sleep mode, allowing for precise power control by software and these features make the ILI9325 an ideal LCD driver for medium or small size portable products such as digital cellular phones, smart phone, PDA and PMP where long battery life is a major concern.

2. Features

- ◆ Single chip solution for a liquid crystal QVGA TFT LCD display
- ◆ 240RGBx320-dot resolution capable with real 262,144 display color
- ◆ Support MVA (Multi-domain Vertical Alignment) wide view display
- ◆ Incorporate 720-channel source driver and 320-channel gate driver
- ◆ Internal 172,800 bytes graphic RAM
- ◆ High-speed RAM burst write function
- ◆ System interfaces
 - i80 system interface with 8-/ 9-/16-/18-bit bus width
 - Serial Peripheral Interface (SPI)
 - RGB interface with 6-/16-/18-bit bus width (VSYNC, HSYNC, DOTCLK, ENABLE, DB[17:0])
 - VSYNC interface (System interface + VSYNC)
- ◆ Internal oscillator and hardware reset
- ◆ Resizing function (×1/2, ×1/4)
- ◆ Reversible source/gate driver shift direction
- ◆ Window address function to specify a rectangular area for internal GRAM access
- ◆ Bit operation function for facilitating graphics data processing
 - Bit-unit write data mask function
 - Pixel-unit logical/conditional write function

- ◆ Abundant functions for color display control
 - γ -correction function enabling display in 262,144 colors
 - Line-unit vertical scrolling function
- ◆ Partial drive function, enabling partially driving an LCD panel at positions specified by user
- ◆ Incorporate step-up circuits for stepping up a liquid crystal drive voltage level up to 6 times (x6)
- ◆ Power saving functions
 - 8-color mode
 - standby mode
 - sleep mode
- ◆ Low -power consumption architecture
 - Low operating power supplies:
 - $IOV_{cc} = 1.65V \sim 3.3 V$ (interface I/O)
 - $V_{ci} = 2.5V \sim 3.3 V$ (analog)
- ◆ LCD Voltage drive:
 - Source/VCOM power supply voltage
 - $DVDH - GND = 4.5V \sim 6.0$
 - $VCL - GND = -2.0V \sim -3.0V$
 - $VCI - VCL \leq 6.0V$
 - Gate driver output voltage
 - $VGH - GND = 10V \sim 20V$
 - $VGL - GND = -5V \sim -15V$
 - $VGH - VGL \leq 32V$
 - VCOM driver output voltage
 - $VCOMH = 3.0V \sim (DDVDH-0.5)V$
 - $VCOML = (VCL+0.5)V \sim 0V$
 - $VCOMH-VCOML \leq 6.0V$
- ◆ a-TFT LCD storage capacitor: Cst only

3. Block Diagram

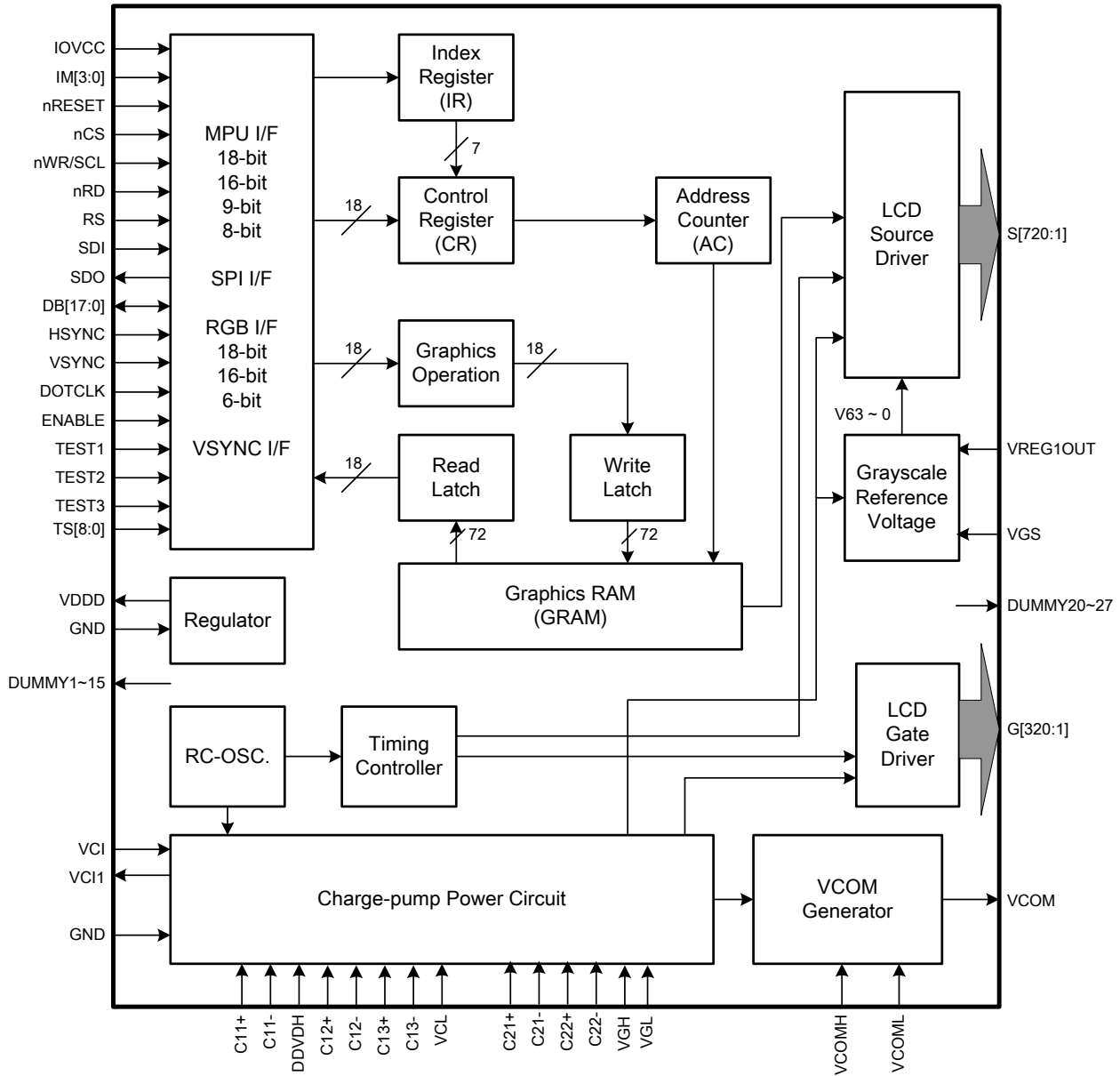

4. Pin Descriptions

Pin Name	I/O	Type	Descriptions																																																																								
Input Interface																																																																											
IM3, IM2, IM1, IM0/ID	I	IOVcc	Select the MPU system interface mode																																																																								
			<table border="1"> <thead> <tr> <th>IM3</th> <th>IM2</th> <th>IM1</th> <th>IM0</th> <th>MPU-Interface Mode</th> <th>DB Pin in use</th> </tr> </thead> <tbody> <tr> <td>0</td> <td>0</td> <td>0</td> <td>0</td> <td>Setting invalid</td> <td></td> </tr> <tr> <td>0</td> <td>0</td> <td>0</td> <td>1</td> <td>Setting invalid</td> <td></td> </tr> <tr> <td>0</td> <td>0</td> <td>1</td> <td>0</td> <td>i80-system 16-bit interface</td> <td>DB[17:10], DB[8:1]</td> </tr> <tr> <td>0</td> <td>0</td> <td>1</td> <td>1</td> <td>i80-system 8-bit interface</td> <td>DB[17:10]</td> </tr> <tr> <td>0</td> <td>1</td> <td>0</td> <td>ID</td> <td>Serial Peripheral Interface (SPI)</td> <td>SDI, SDO</td> </tr> <tr> <td>0</td> <td>1</td> <td>1</td> <td>*</td> <td>Setting invalid</td> <td></td> </tr> <tr> <td>1</td> <td>0</td> <td>0</td> <td>0</td> <td>Setting invalid</td> <td></td> </tr> <tr> <td>1</td> <td>0</td> <td>0</td> <td>1</td> <td>Setting invalid</td> <td></td> </tr> <tr> <td>1</td> <td>0</td> <td>1</td> <td>0</td> <td>i80-system 18-bit interface</td> <td>DB[17:0]</td> </tr> <tr> <td>1</td> <td>0</td> <td>1</td> <td>1</td> <td>i80-system 9-bit interface</td> <td>DB[17:9]</td> </tr> <tr> <td>1</td> <td>1</td> <td>*</td> <td>*</td> <td>Setting invalid</td> <td></td> </tr> </tbody> </table>	IM3	IM2	IM1	IM0	MPU-Interface Mode	DB Pin in use	0	0	0	0	Setting invalid		0	0	0	1	Setting invalid		0	0	1	0	i80-system 16-bit interface	DB[17:10], DB[8:1]	0	0	1	1	i80-system 8-bit interface	DB[17:10]	0	1	0	ID	Serial Peripheral Interface (SPI)	SDI, SDO	0	1	1	*	Setting invalid		1	0	0	0	Setting invalid		1	0	0	1	Setting invalid		1	0	1	0	i80-system 18-bit interface	DB[17:0]	1	0	1	1	i80-system 9-bit interface	DB[17:9]	1	1	*	*	Setting invalid	
			IM3	IM2	IM1	IM0	MPU-Interface Mode	DB Pin in use																																																																			
			0	0	0	0	Setting invalid																																																																				
			0	0	0	1	Setting invalid																																																																				
			0	0	1	0	i80-system 16-bit interface	DB[17:10], DB[8:1]																																																																			
			0	0	1	1	i80-system 8-bit interface	DB[17:10]																																																																			
			0	1	0	ID	Serial Peripheral Interface (SPI)	SDI, SDO																																																																			
			0	1	1	*	Setting invalid																																																																				
			1	0	0	0	Setting invalid																																																																				
			1	0	0	1	Setting invalid																																																																				
			1	0	1	0	i80-system 18-bit interface	DB[17:0]																																																																			
1	0	1	1	i80-system 9-bit interface	DB[17:9]																																																																						
1	1	*	*	Setting invalid																																																																							
			When the serial peripheral interface is selected, IM0 pin is used for the device code ID setting.																																																																								
nCS	I	MPU IOVcc	A chip select signal. Low: the ILI9325 is selected and accessible High: the ILI9325 is not selected and not accessible Fix to the GND level when not in use.																																																																								
RS	I	MPU IOVcc	A register select signal. Low: select an index or status register High: select a control register Fix to either IOVcc or GND level when not in use.																																																																								
nWR/SCL	I	MPU IOVcc	A write strobe signal and enables an operation to write data when the signal is low. Fix to either IOVcc or GND level when not in use. SPI Mode: Synchronizing clock signal in SPI mode.																																																																								
nRD	I	MPU IOVcc	A read strobe signal and enables an operation to read out data when the signal is low. Fix to either IOVcc or GND level when not in use.																																																																								
nRESET	I	MPU IOVcc	A reset pin. Initializes the ILI9325 with a low input. Be sure to execute a power-on reset after supplying power.																																																																								
SDI	I	MPU IOVcc	SPI interface input pin. The data is latched on the rising edge of the SCL signal.																																																																								
SDO	O	MPU IOVcc	SPI interface output pin. The data is outputted on the falling edge of the SCL signal. Let SDO as floating when not used.																																																																								
DB[17:0]	I/O	MPU IOVcc	An 18-bit parallel bi-directional data bus for MPU system interface mode 8-bit I/F: DB[17:10] is used. 9-bit I/F: DB[17:9] is used. 16-bit I/F: DB[17:10] and DB[8:1] is used. 18-bit I/F: DB[17:0] is used. 18-bit parallel bi-directional data bus for RGB interface operation 6-bit RGB I/F: DB[17:12] are used.																																																																								

Pin Name	I/O	Type	Descriptions
			16-bit RGB I/F: DB[17:13] and DB[11:1] are used. 18-bit RGB I/F: DB[17:0] are used. Unused pins must be fixed to GND level.
ENABLE	I	MPU IOVcc	Data ENEABLE signal for RGB interface operation. Low: Select (access enabled) High: Not select (access inhibited) The EPL bit inverts the polarity of the ENABLE signal. Fix to either IOVcc or GND level when not in use.
DOTCLK	I	MPU IOVcc	Dot clock signal for RGB interface operation. DPL = "0": Input data on the rising edge of DOTCLK DPL = "1": Input data on the falling edge of DOTCLK Fix to the GND level when not in use
VSYNC	I	MPU IOVcc	Frame synchronizing signal for RGB interface operation. VSPL = "0": Active low. VSPL = "1": Active high. Fix to the GND level when not in use.
HSYNC	I	MPU IOVcc	Line synchronizing signal for RGB interface operation. HSPL = "0": Active low. HSPL = "1": Active high. Fix to the GND level when not in use
FMARK	O	MPU IOVcc	Output a frame head pulse signal. The FMARK signal is used when writing RAM data in synchronization with frame. Leave the pin open when not in use.
LCD Driving signals			
S720~S1	O	LCD	Source output voltage signals applied to liquid crystal. To change the shift direction of signal outputs, use the SS bit. SS = "0", the data in the RAM address "h00000" is output from S1. SS = "1", the data in the RAM address "h00000" is output from S720. S1, S4, S7, ... display red (R), S2, S5, S8, ... display green (G), and S3, S6, S9, ... display blue (B) (SS = 0).
G320~G1	O	LCD	Gate line output signals. VGH: the level selecting gate lines VGL: the level not selecting gate lines
VCOM	O	TFT common electrode	A supply voltage to the common electrode of TFT panel. VCOM is AC voltage alternating signal between the VCOMH and VCOML levels.
VCOMH	O	Stabilizing capacitor	The high level of VCOM AC voltage. Connect to a stabilizing capacitor.
VCOML	O	Stabilizing capacitor	The low level of VCOM AC voltage. Adjust the VCOML level with the VDV bits. Connect to a stabilizing capacitor.
VGS	I	GND or external resistor	Reference level for the grayscale voltage generating circuit. The VGS level can be changed by connecting to an external resistor.
Charge-pump and Regulator Circuit			
Vci	I	Power supply	A supply voltage to the analog circuit. Connect to an external power supply of 2.5 ~ 3.3V.
GND	I	Power supply	GND for the analog side: GND = 0V. In case of COG, connect to GND on the FPC to prevent noise.
Vci1	O	Stabilizing capacitor	An internal reference voltage for the step-up circuit1. The amplitude between Vci and GND is determined by the VC[2:0] bits. Make sure to set the Vci1 voltage so that the DDVDH, VGH and VGL voltages are set within the respective specification.
DDVDH	O	Stabilizing	Power supply for the source driver and Vcom drive.

Pin Name	I/O	Type	Descriptions
		capacitor	
VGH	I	Stabilizing capacitor	Power supply for the gate driver.
VGL	I	Stabilizing capacitor	Power supply for the gate driver.
VCL	O	Stabilizing capacitor	VcomL driver power supply. VCL = 0.5 ~ -VCI . Place a stabilizing capacitor between GND
C11+, C11- C12+, C12-	I/O	Step-up capacitor	Capacitor connection pins for the step-up circuit 1.
C13+, C13- C21+, C21- C22+, C22-	I/O	Step-up capacitor	Capacitor connection pins for the step-up circuit 2.
VREG1OUT	I/O	Stabilizing capacitor	Output voltage generated from the reference voltage. The voltage level is set with the VRH bits. VREG1OUT is (1) a source driver grayscale reference voltage, (2) VcomH level reference voltage, and (3) Vcom amplitude reference voltage. Connect to a stabilizing capacitor. VREG1OUT = 3.0 ~ (DDVDH - 0.5)V.
Power Pads			
IOVcc	I	Power supply	A supply voltage to the interface pins: IM[3:0], nRESET, nCS, nWR, nRD, RS, DB[17:0], VSYNC, HSYNC, DOTCLK, ENABLE, SCL, SDI, SDO. IOVcc = 1.65 ~ 3.3V and Vcc ≥ IOVcc. In case of COG, connect to Vcc on the FPC if IOVcc=Vcc, to prevent noise.
VDDD	O	Power	Digital circuit power pad. Connect these pins with the 1uF capacitor.
GND	I	Power supply	GND = 0V.
Test Pads			
DUMMY1~ 15 DUMMY20 ~ 27	-	-	Dummy pad. Leave these pins as open.
IOGNDDUM	O	GND	GND pin.
TESTO1~16	O	Open	Test pins. Leave them open.
TEST1, 2, 3	I	IOGND	Test pins (internal pull low). Connect to GND or leave these pins as open.
TS0~8	I	OPEN	Test pins (internal pull low). Leave them open.

Liquid crystal power supply specifications Table 1

No.	Item	Description
1	TFT Source Driver	720 pins (240 x RGB)
2	TFT Gate Driver	320 pins
3	TFT Display's Capacitor Structure	Cst structure only (Common VCOM)
4	Liquid Crystal Drive Output	S1 ~ S720
		G1 ~ G320
		VCOM
5	Input Voltage	IOVcc
		Vci

6	Liquid Crystal Drive Voltages	DDVDH	4.5V ~ 6.0V
		VGH	10V ~ 20V
		VGL	-5V ~ -15V
		VCL	-1.9V ~ -3.0V
		VGH - VGL	Max. 32V
		Vci - VCL	Max. 6.0V
7	Internal Step-up Circuits	DDVDH	Vci1 x2
		VGH	Vci1 x4, x5, x6
		VGL	Vci1 x-3, x-4, x-5
		VCL	Vci1 x-1

5. Pad Arrangement and Coordination

Chip Size: 17820um x 870um

Chip thickness : 280um or 400um (typ.)

Pad Location: Pad Center.

Coordinate Origin: Chip center

Au bump height: 15um (typ.)

Au Bump Size:

- 16um x 98um
Gate: G1 ~ G320
Source: S1 ~ S720

- 50um x 80um
Input Pads
Pad 1 to 243.

Alignment Marks

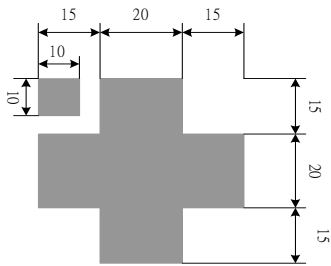

Alignment Mark: A1

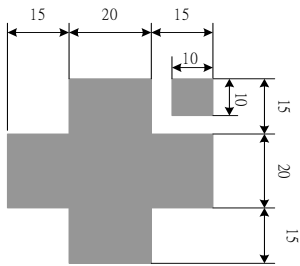

Alignment Mark: A2

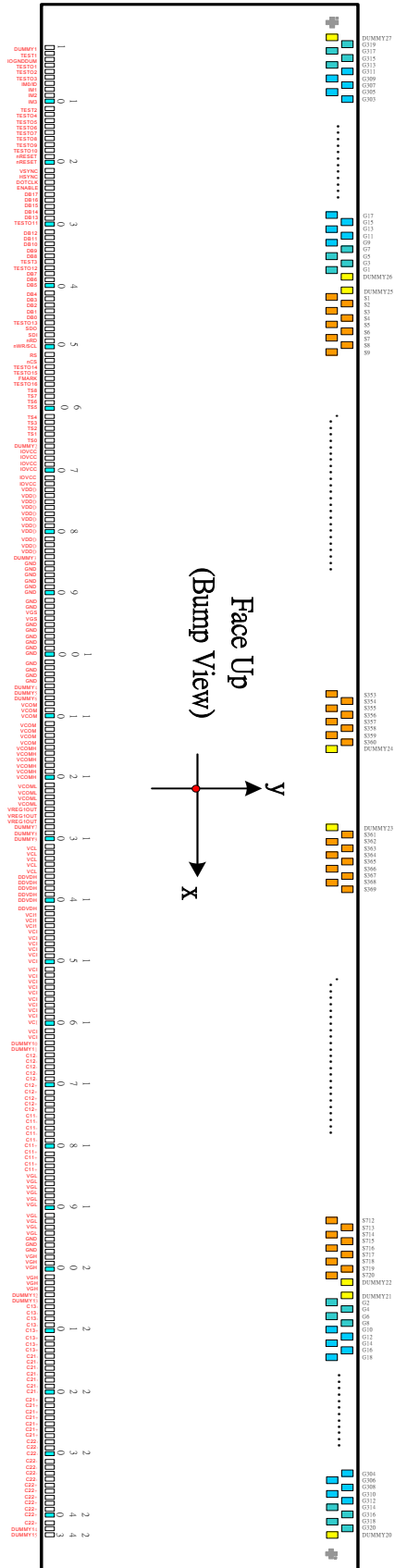
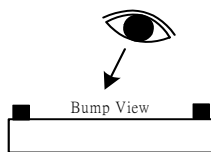

No.	Name	X	Y	No.	Name	X	Y
1201	G141	-7219	202.5	1261	G261	-8179	202.5
1202	G143	-7235	319.5	1262	G263	-8195	319.5
1203	G145	-7251	202.5	1263	G265	-8211	202.5
1204	G147	-7267	319.5	1264	G267	-8227	319.5
1205	G149	-7283	202.5	1265	G269	-8243	202.5
1206	G151	-7299	319.5	1266	G271	-8259	319.5
1207	G153	-7315	202.5	1267	G273	-8275	202.5
1208	G155	-7331	319.5	1268	G275	-8291	319.5
1209	G157	-7347	202.5	1269	G277	-8307	202.5
1210	G159	-7363	319.5	1270	G279	-8323	319.5
1211	G161	-7379	202.5	1271	G281	-8339	202.5
1212	G163	-7395	319.5	1272	G283	-8355	319.5
1213	G165	-7411	202.5	1273	G285	-8371	202.5
1214	G167	-7427	319.5	1274	G287	-8387	319.5
1215	G169	-7443	202.5	1275	G289	-8403	202.5
1216	G171	-7459	319.5	1276	G291	-8419	319.5
1217	G173	-7475	202.5	1277	G293	-8435	202.5
1218	G175	-7491	319.5	1278	G295	-8451	319.5
1219	G177	-7507	202.5	1279	G297	-8467	202.5
1220	G179	-7523	319.5	1280	G299	-8483	319.5
1221	G181	-7539	202.5	1281	G301	-8499	202.5
1222	G183	-7555	319.5	1282	G303	-8515	319.5
1223	G185	-7571	202.5	1283	G305	-8531	202.5
1224	G187	-7587	319.5	1284	G307	-8547	319.5
1225	G189	-7603	202.5	1285	G309	-8563	202.5
1226	G191	-7619	319.5	1286	G311	-8579	319.5
1227	G193	-7635	202.5	1287	G313	-8595	202.5
1228	G195	-7651	319.5	1288	G315	-8611	319.5
1229	G197	-7667	202.5	1289	G317	-8627	202.5
1230	G199	-7683	319.5	1290	G319	-8643	319.5
1231	G201	-7699	202.5	1291	DUMMY27	-8659	202.5
1232	G203	-7715	319.5	Alignment mark		X	Y
1233	G205	-7731	202.5		1-a	-8751	269
1234	G207	-7747	319.5		1-b	8751	269
1235	G209	-7763	202.5				
1236	G211	-7779	319.5				
1237	G213	-7795	202.5				
1238	G215	-7811	319.5				
1239	G217	-7827	202.5				
1240	G219	-7843	319.5				
1241	G221	-7859	202.5				
1242	G223	-7875	319.5				
1243	G225	-7891	202.5				
1244	G227	-7907	319.5				
1245	G229	-7923	202.5				
1246	G231	-7939	319.5				
1247	G233	-7955	202.5				
1248	G235	-7971	319.5				
1249	G237	-7987	202.5				
1250	G239	-8003	319.5				
1251	G241	-8019	202.5				
1252	G243	-8035	319.5				
1253	G245	-8051	202.5				
1254	G247	-8067	319.5				
1255	G249	-8083	202.5				
1256	G251	-8099	319.5				
1257	G253	-8115	202.5				
1258	G255	-8131	319.5				
1259	G257	-8147	202.5				
1260	G259	-8163	319.5				

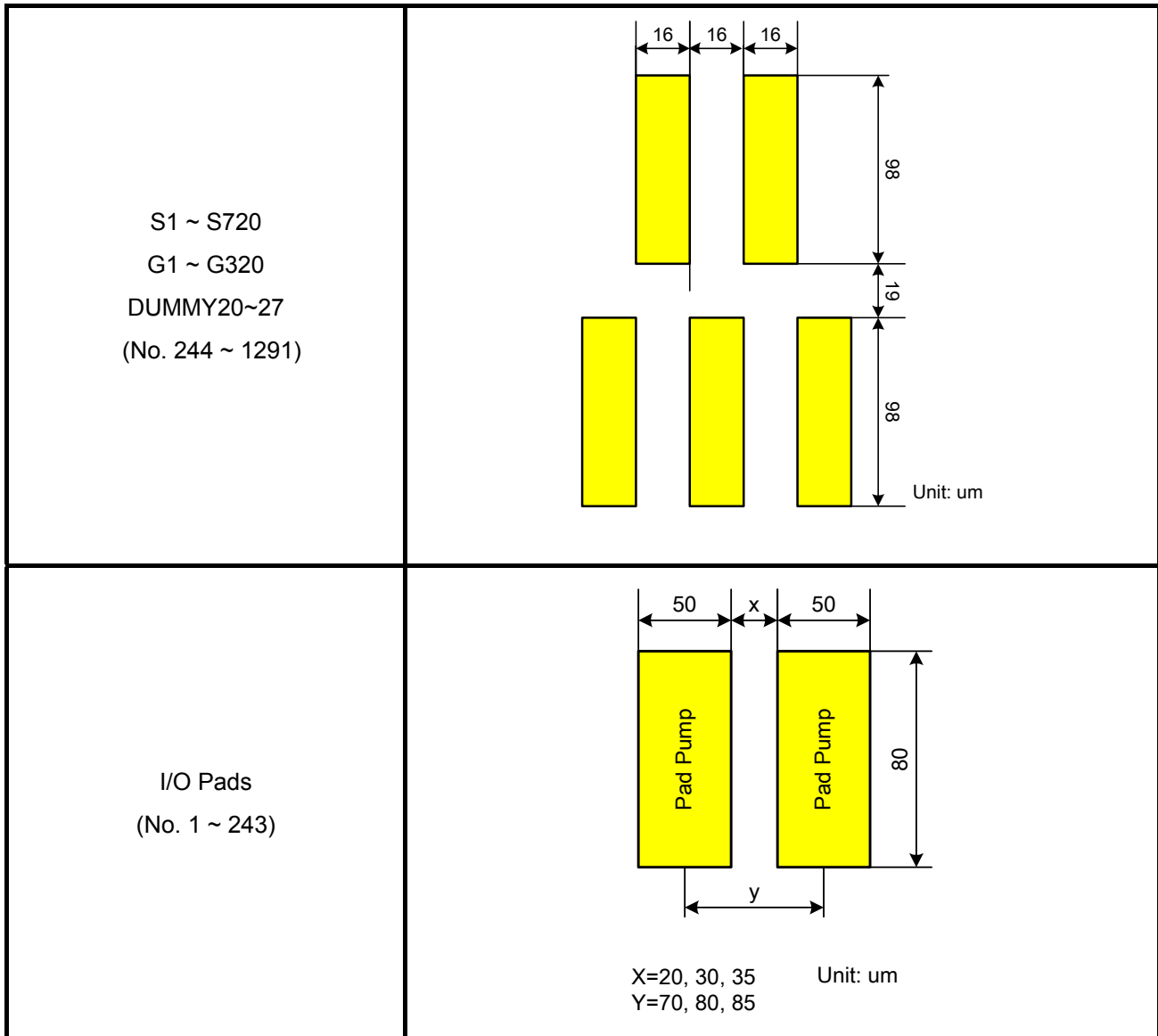

6. Block Description

MPU System Interface

ILI9325 supports three system high-speed interfaces: i80-system high-speed interfaces to 8-, 9-, 16-, 18-bit parallel ports and serial peripheral interface (SPI). The interface mode is selected by setting the IM[3:0] pins.

ILI9325 has a 16-bit index register (IR), an 18-bit write-data register (WDR), and an 18-bit read-data register (RDR). The IR is the register to store index information from control registers and the internal GRAM. The WDR is the register to temporarily store data to be written to control registers and the internal GRAM. The RDR is the register to temporarily store data read from the GRAM. Data from the MPU to be written to the internal GRAM are first written to the WDR and then automatically written to the internal GRAM in internal operation. Data are read via the RDR from the internal GRAM. Therefore, invalid data are read out to the data bus when the ILI9325 read the first data from the internal GRAM. Valid data are read out after the ILI9325 performs the second read operation.

Registers are written consecutively as the register execution time except starting oscillator takes 0 clock cycle.

Registers selection by system interface (8-/9-/16-/18-bit bus width)				I80
Function	RS	nWR	nRD	
Write an index to IR register	0	0	1	
Read an internal status	0	1	0	
Write to control registers or the internal GRAM by WDR register.	1	0	1	
Read from the internal GRAM by RDR register.	1	1	0	

Registers selection by the SPI system interface			
Function	R/W	RS	
Write an index to IR register	0	0	
Read an internal status	1	0	
Write to control registers or the internal GRAM by WDR register.	0	1	
Read from the internal GRAM by RDR register.	1	1	

Parallel RGB Interface

ILI9325 supports the RGB interface and the VSYNC interface as the external interface for displaying a moving picture. When the RGB interface is selected, display operations are synchronized with externally supplied signals, VSYNC, HSYNC, and DOTCLK. In RGB interface mode, data (DB17-0) are written in synchronization with these signals according to the polarity of enable signal (ENABLE) to prevent flicker on display while updating display data.

In VSYNC interface mode, the display operation is synchronized with the internal clock except frame synchronization, where the operation is synchronized with the VSYNC signal. Display data are written to the internal GRAM via the system interface. In this case, there are constraints in speed and method in writing data to the internal RAM. For details, see the "External Display Interface" section. The ILI9325 allows for switching between the external display interface and the system interface by instruction so that the optimum interface is

selected for the kind of picture to be displayed on the screen (still and/or moving picture(s)). The RGB interface, by writing all display data to the internal RAM, allows for transferring data only when updating the frames of a moving picture, contributing to low power requirement for moving picture display.

Bit Operation

The ILI9325 supports a write data mask function for selectively writing data to the internal RAM in units of bits and a logical/compare operation to write data to the GRAM only when a condition is met as a result of comparing the data and the compare register bits. For details, see “Graphics Operation Functions”.

Address Counter (AC)

The address counter (AC) gives an address to the internal GRAM. When the index of the register for setting a RAM address in the AC is written to the IR, the address information is sent from the IR to the AC. As writing data to the internal GRAM, the address in the AC is automatically updated plus or minus 1. The window address function enables writing data only in the rectangular area arbitrarily set by users on the GRAM.

Graphics RAM (GRAM)

GRAM is graphics RAM storing bit-pattern data of 172,820 (240 x 320x 18/8) bytes with 18 bits per pixel.

Grayscale Voltage Generating Circuit

The grayscale voltage generating circuit generates a liquid crystal drive voltage according to grayscale data set in the γ -correction register to display in 262,144 colors. For details, see the “ γ -Correction Register” section.

Timing Controller

The timing generator generates a timing signal for operation of internal circuits such as the internal GRAM. The timing for the display operation such as RAM read operation and the timing for the internal operation such as access from the MPU are generated in the way not to interfere each other.

Oscillator (OSC)

ILI9325 generates RC oscillation with an internal oscillation resistor. The frame rate is adjusted by the register setting.

LCD Driver Circuit

The LCD driver circuit of ILI9325 consists of a 720-output source driver (S1 ~ S720) and a 320-output gate driver (G1~G320). Display pattern data are latched when the 720th bit data are input. The latched data control the source driver and generate a drive waveform. The gate driver for scanning gate lines outputs either VGH or VGL level. The shift direction of 720 source outputs from the source driver is set with the SS bit and the shift direction of gate outputs from the gate driver is set with the GS bit. The scan mode by the gate driver is

set with the SM bit. These bits allow setting an appropriate scan method for an LCD module.

LCD Driver Power Supply Circuit

The LCD drive power supply circuit generates the voltage levels VREG1OUT, VGH, VGL and Vcom for driving an LCD.

7. System Interface

7.1. Interface Specifications

ILI9325 has the system interface to read/write the control registers and display graphics memory (GRAM), and the RGB Input Interface for displaying a moving picture. User can select an optimum interface to display the moving or still picture with efficient data transfer. All display data are stored in the GRAM to reduce the data transfer efforts and only the updating data is necessary to be transferred. User can only update a sub-range of GRAM by using the window address function.

ILI9325 also has the RGB interface and VSYNC interface to transfer the display data without flicker the moving picture on the screen. In RGB interface mode, the display data is written into the GRAM through the control signals of ENABLE, VSYNC, HSYNC, DOTCLK and data bus DB[17:0].

In VSYNC interface mode, the internal display timing is synchronized with the frame synchronization signal (VSYNC). The VSYNC interface mode enables to display the moving picture display through the system interface. In this case, there are some constraints of speed and method to write data to the internal RAM.

ILI9325 operates in one of the following 4 modes. The display mode can be switched by the control register. When switching from one mode to another, refer to the sequences mentioned in the sections of RGB and VSYNC interfaces.

Operation Mode	RAM Access Setting (RM)	Display Operation Mode (DM[1:0])
Internal operating clock only (Displaying still pictures)	System interface (RM = 0)	Internal operating clock (DM[1:0] = 00)
RGB interface (1) (Displaying moving pictures)	RGB interface (RM = 1)	RGB interface (DM[1:0] = 01)
RGB interface (2) (Rewriting still pictures while displaying moving pictures)	System interface (RM = 0)	RGB interface (DM[1:0] = 01)
VSYNC interface (Displaying moving pictures)	System interface (RM = 0)	VSYNC interface (DM[1:0] = 01)

Note 1) Registers are set only via the system interface.

Note 2) The RGB-I/F and the VSYNC-I/F are not available simultaneously.

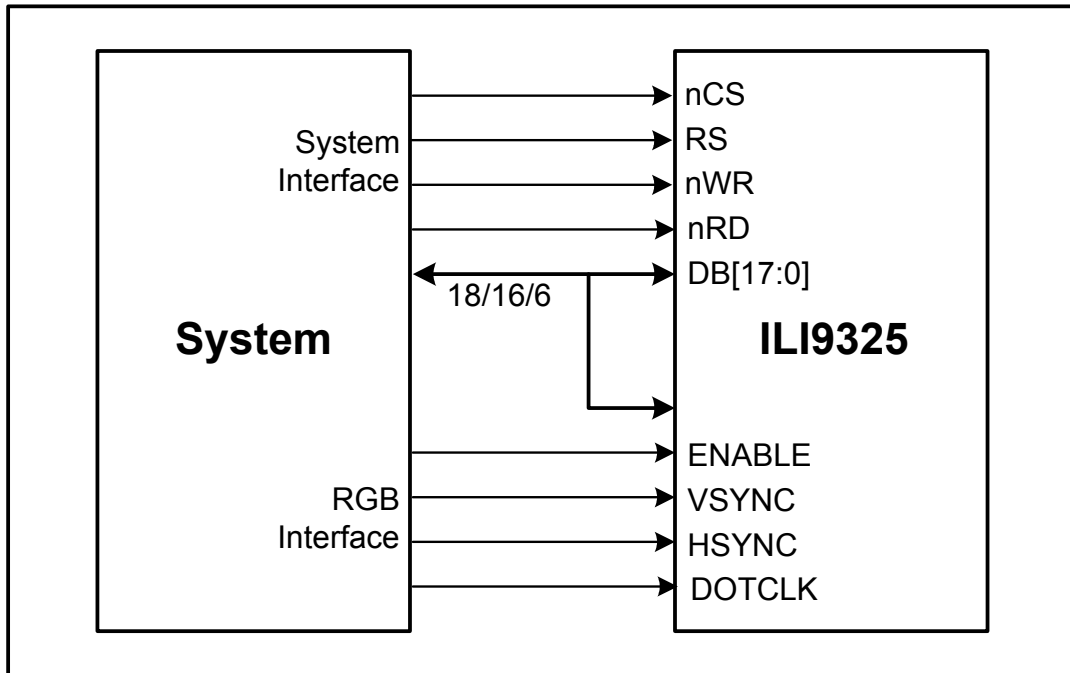

Figure1 System Interface and RGB Interface connection

7.2. Input Interfaces

The following are the system interfaces available with the ILI9325. The interface is selected by setting the IM[3:0] pins. The system interface is used for setting registers and GRAM access.

IM3	IM2	IM1	IM0/ID	Interface Mode	DB Pin
0	0	0	0	Setting invalid	
0	0	0	1	Setting invalid	
0	0	1	0	i80-system 16-bit interface	DB[17:10], DB[8:1]
0	0	1	1	i80-system 8-bit interface	DB[17:10]
0	1	0	ID	Serial Peripheral Interface (SPI)	SDI, SDO (DB[1:0])
0	1	1	*	Setting invalid	
1	0	0	0	Setting invalid	
1	0	0	1	Setting invalid	
1	0	1	0	i80-system 18-bit interface	DB[17:0]
1	0	1	1	i80-system 9-bit interface	DB[17:9]
1	1	*	*	Setting invalid	

7.2.1. i80/18-bit System Interface

The i80/18-bit system interface is selected by setting the IM[3:0] as “1010” levels.

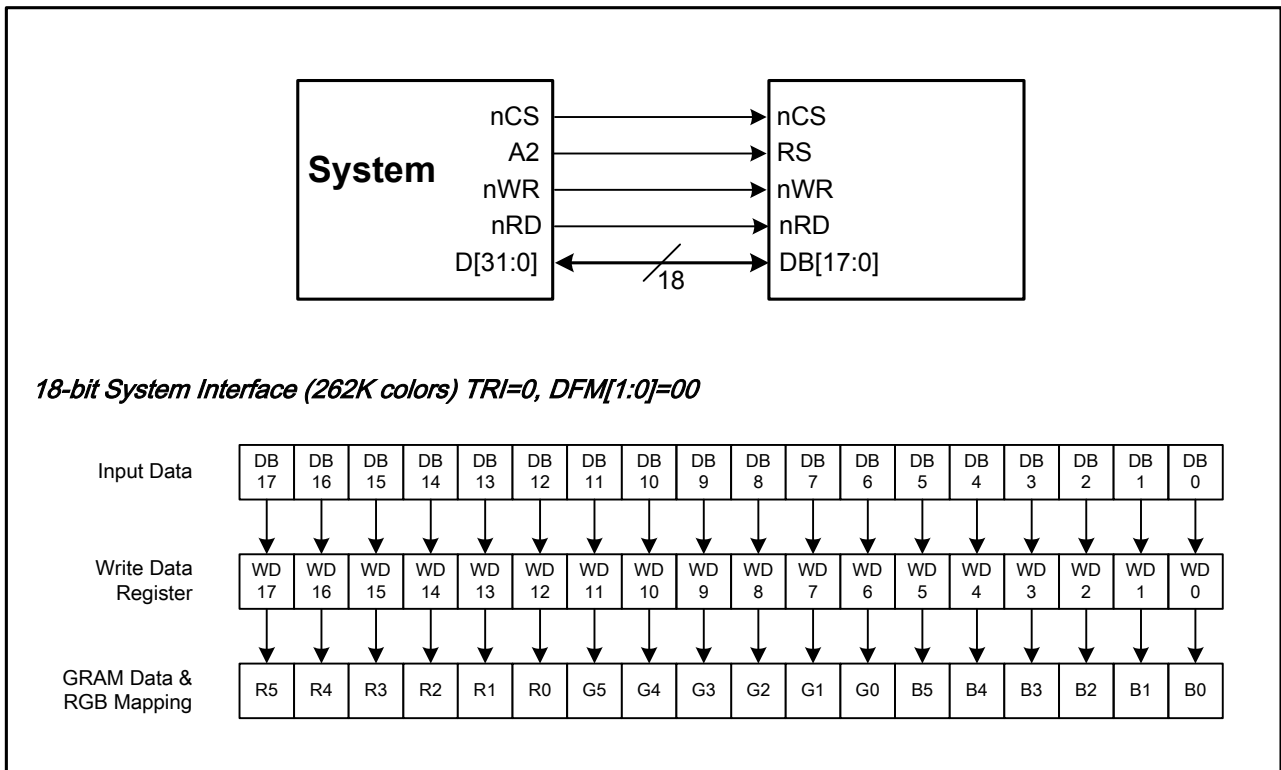

Figure2 18-bit System Interface Data Format

7.2.2. i80/16-bit System Interface

The i80/16-bit system interface is selected by setting the IM[3:0] as “0010” levels. The 262K or 65K color can be display through the 16-bit MPU interface. When the 262K color is displayed, two transfers (1st transfer: 2 bits, 2nd transfer: 16 bits or 1st transfer: 16 bits, 2nd transfer: 2 bits) are necessary for the 16-bit CPU interface.

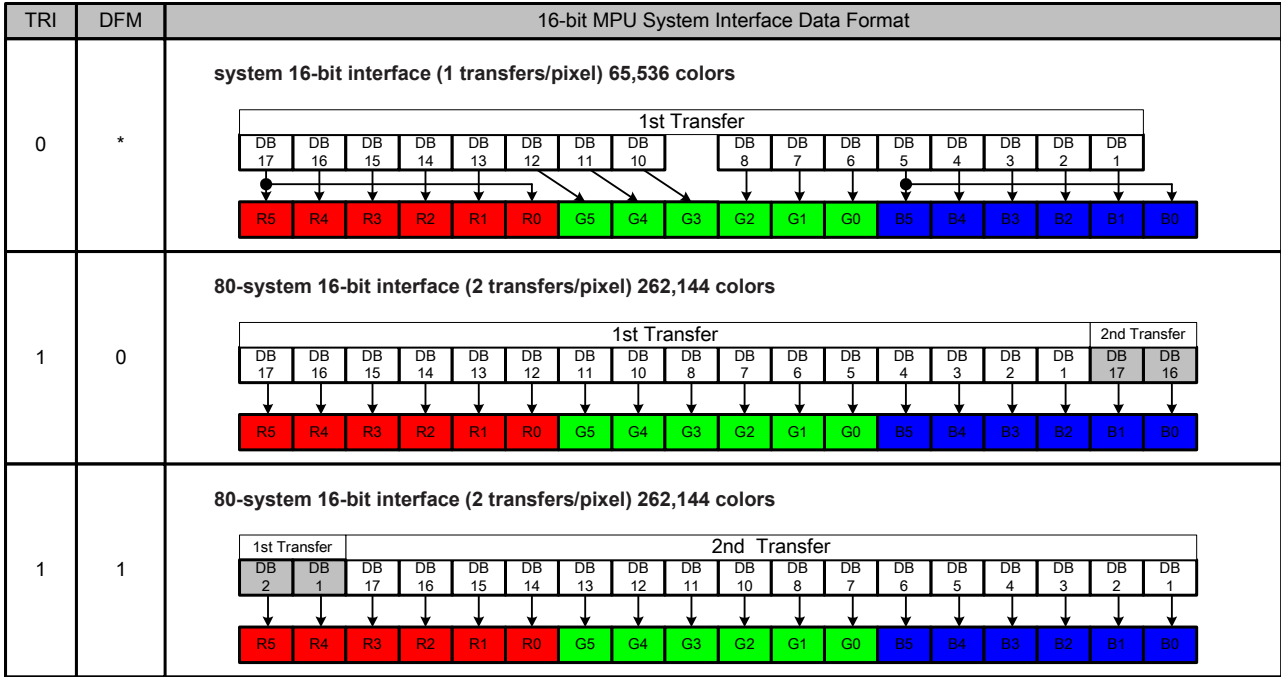

Figure3 16-bit System Interface Data Format

7.2.3. i80/9-bit System Interface

The i80/9-bit system interface is selected by setting the IM[3:0] as “1011” and the DB17~DB9 pins are used to transfer the data. When writing the 16-bit register, the data is divided into upper byte (8 bits and LSB is not used) lower byte and the upper byte is transferred first. The display data is also divided in upper byte (9 bits) and lower byte, and the upper byte is transferred first. The unused DB[8:0] pins must be tied to GND.

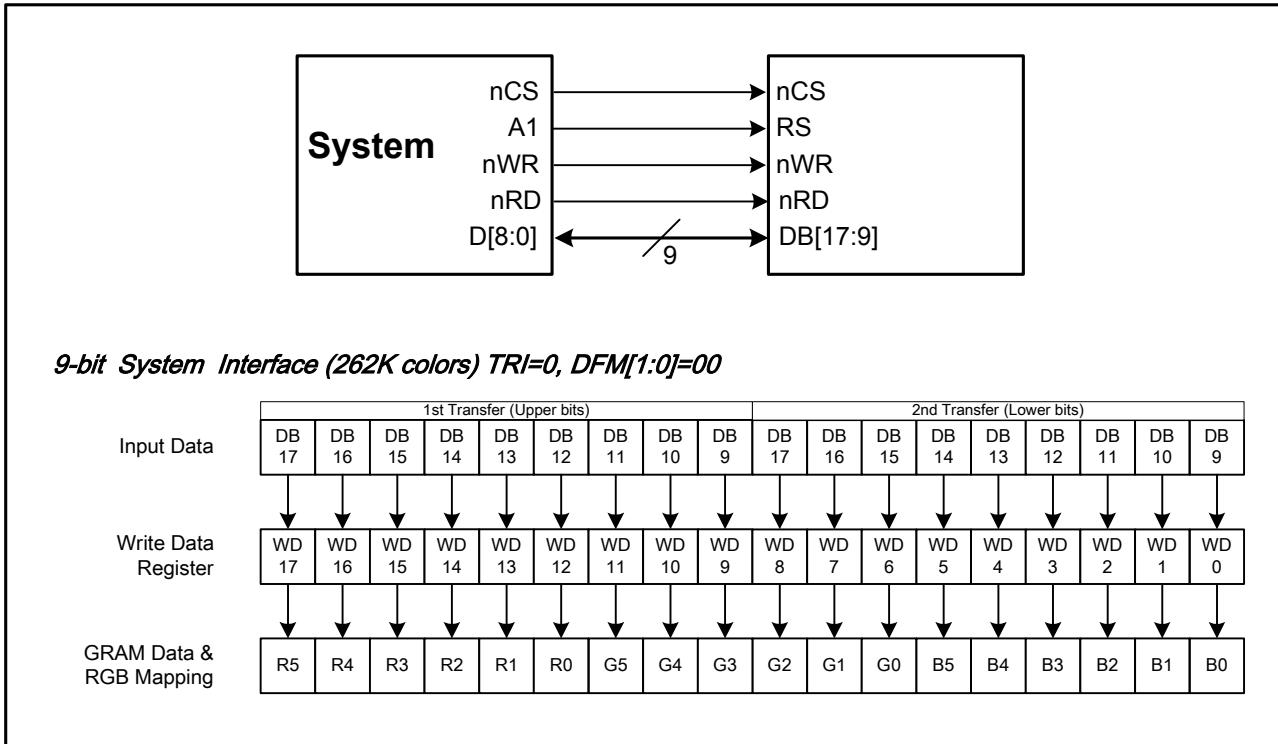

Figure4 9-bit System Interface Data Format

7.2.4. i80/8-bit System Interface

The i80/8-bit system interface is selected by setting the IM[3:0] as “0011” and the DB17~DB10 pins are used to transfer the data. When writing the 16-bit register, the data is divided into upper byte (8 bits and LSB is not used) lower byte and the upper byte is transferred first. The display data is also divided in upper byte (8 bits) and lower byte, and the upper byte is transferred first. The written data is expanded into 18 bits internally (see the figure below) and then written into GRAM. The unused DB[9:0] pins must be tied to GND.

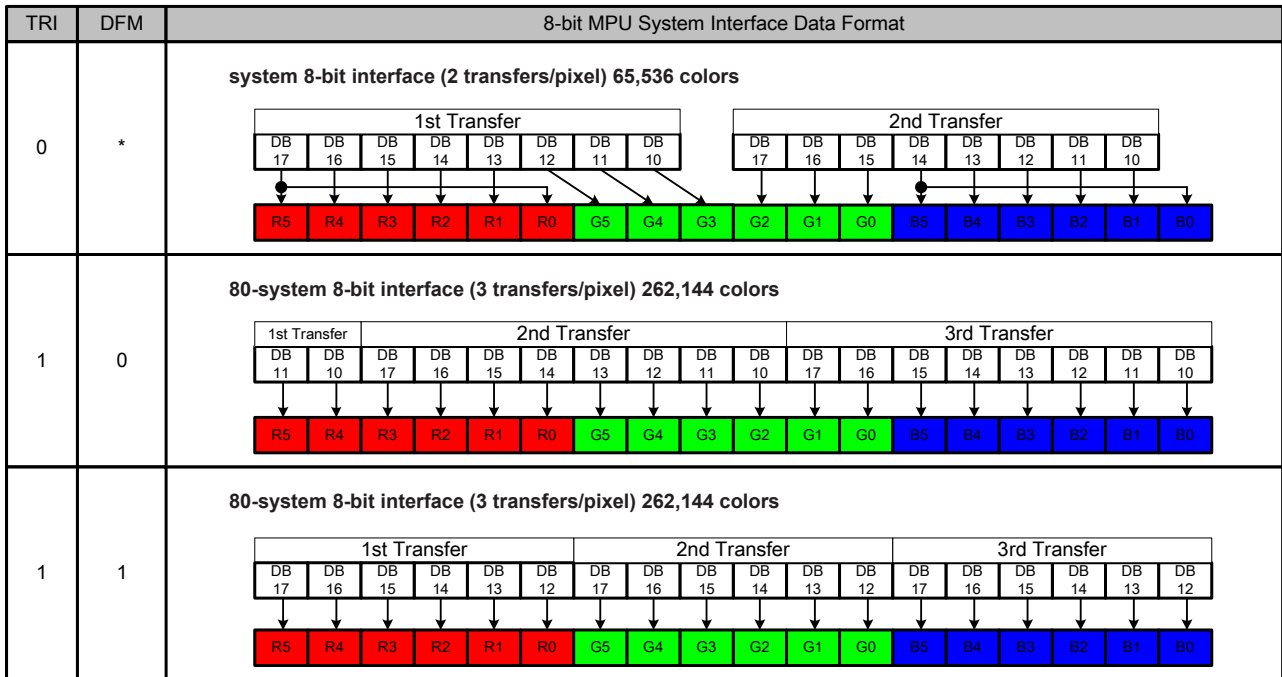

Figure5 8-bit System Interface Data Format

Data transfer synchronization in 8/9-bit bus interface mode

ILI9325 supports a data transfer synchronization function to reset upper and lower counters which count the transfers numbers of upper and lower byte in 8/9-bit interface mode. If a mismatch arises in the numbers of transfers between the upper and lower byte counters due to noise and so on, the “00”h register is written 4 times consecutively to reset the upper and lower counters so that data transfer will restart with a transfer of upper byte. This synchronization function can effectively prevent display error if the upper/lower counters are periodically reset.

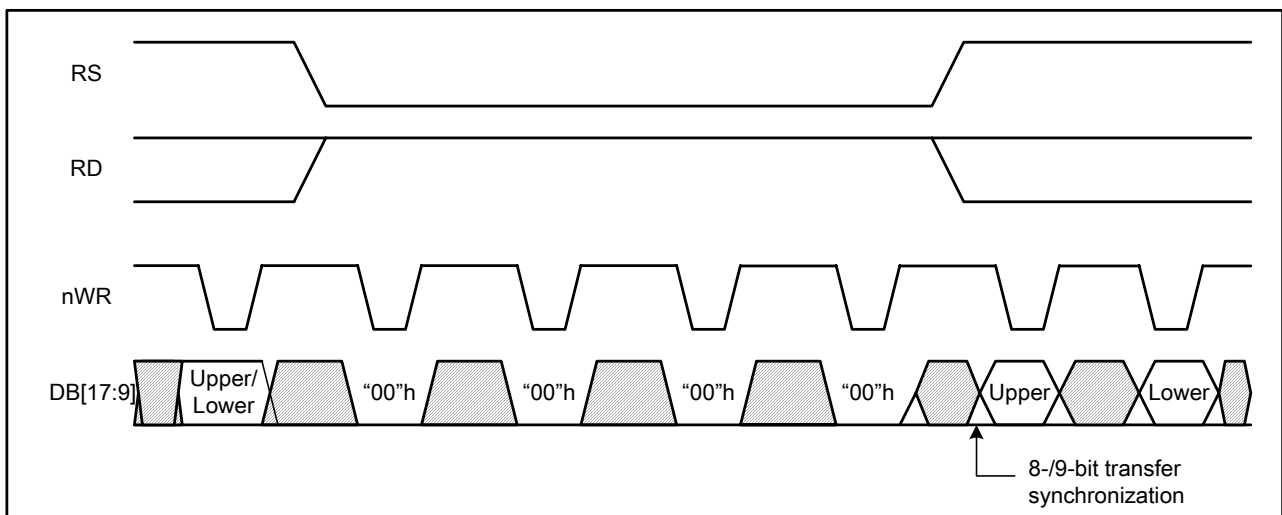

Figure6 Data Transfer Synchronization in 8/9-bit System Interface

7.3. Serial Peripheral Interface (SPI)

The Serial Peripheral Interface (SPI) is selected by setting the IM[3:0] pins as “010x” level. The chip select pin

(nCS), the serial transfer clock pin (SCL), the serial data input pin (SDI) and the serial data output pin (SDO) are used in SPI mode. The ID pin sets the least significant bit of the identification code. The DB[17:0] pins, which are not used, must be tied to GND.

The SPI interface operation enables from the falling edge of nCS and ends of data transfer on the rising edge of nCS. The start byte is transferred to start the SPI interface and the read/write operation and RS information are also included in the start byte. When the start byte is matched, the subsequent data is received by ILI9325.

The seventh bit of start byte is RS bit. When RS = "0", either index write operation or status read operation is executed. When RS = "1", either register write operation or RAM read/write operation is executed. The eighth bit of the start byte is used to select either read or write operation (R/W bit). Data is written when the R/W bit is "0" and read back when the R/W bit is "1".

After receiving the start byte, ILI9325 starts to transfer or receive the data in unit of byte and the data transfer starts from the MSB bit. All the registers of the ILI9325 are 16-bit format and receive the first and the second byte data as the upper and the lower eight bits of the 16-bit register respectively. In SPI mode, 5 bytes dummy read is necessary and the valid data starts from 6th byte of read back data.

Start Byte Format

Transferred bits	S	1	2	3	4	5	6	7	8	
Start byte format	Transfer start	Device ID code					RS	R/W		
		0	1	1	1	0	ID	1/0	1/0	

Note: ID bit is selected by setting the IM0/ID pin.

RS and R/W Bit Function

RS	R/W	Function
0	0	Set an index register
0	1	Read a status
1	0	Write a register or GRAM data
1	1	Read a register or GRAM data

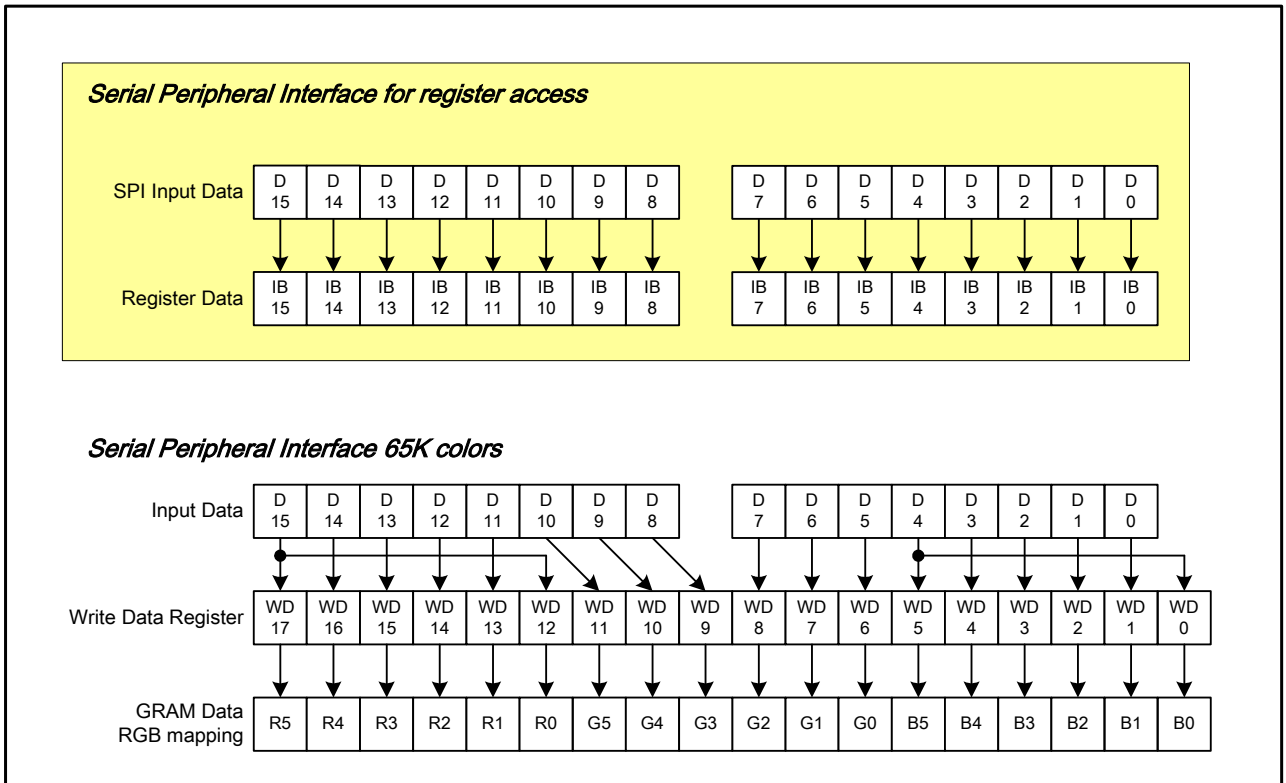

Figure 7 Data Format of SPI Interface

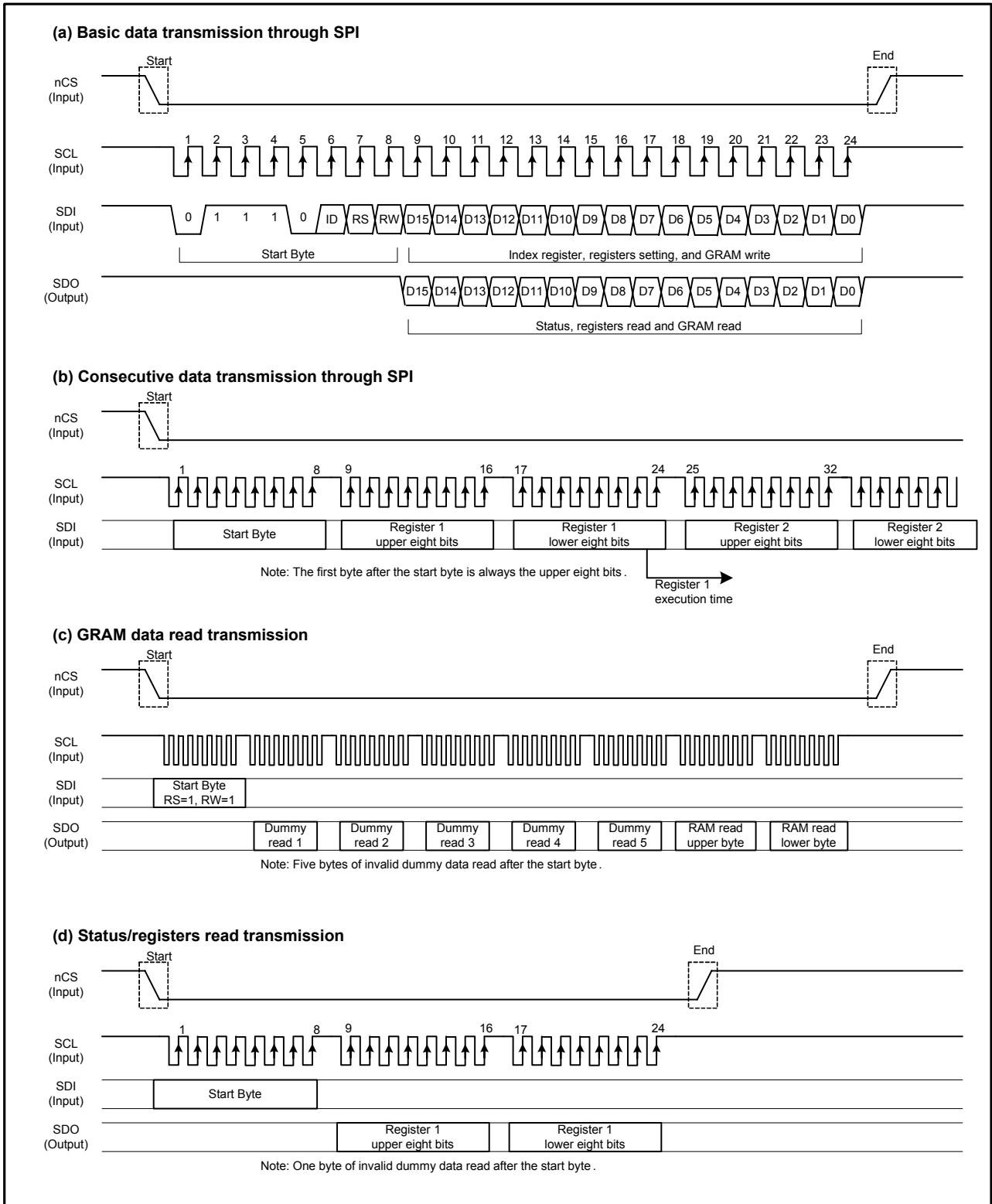

Figure8 Data transmission through serial peripheral interface (SPI)

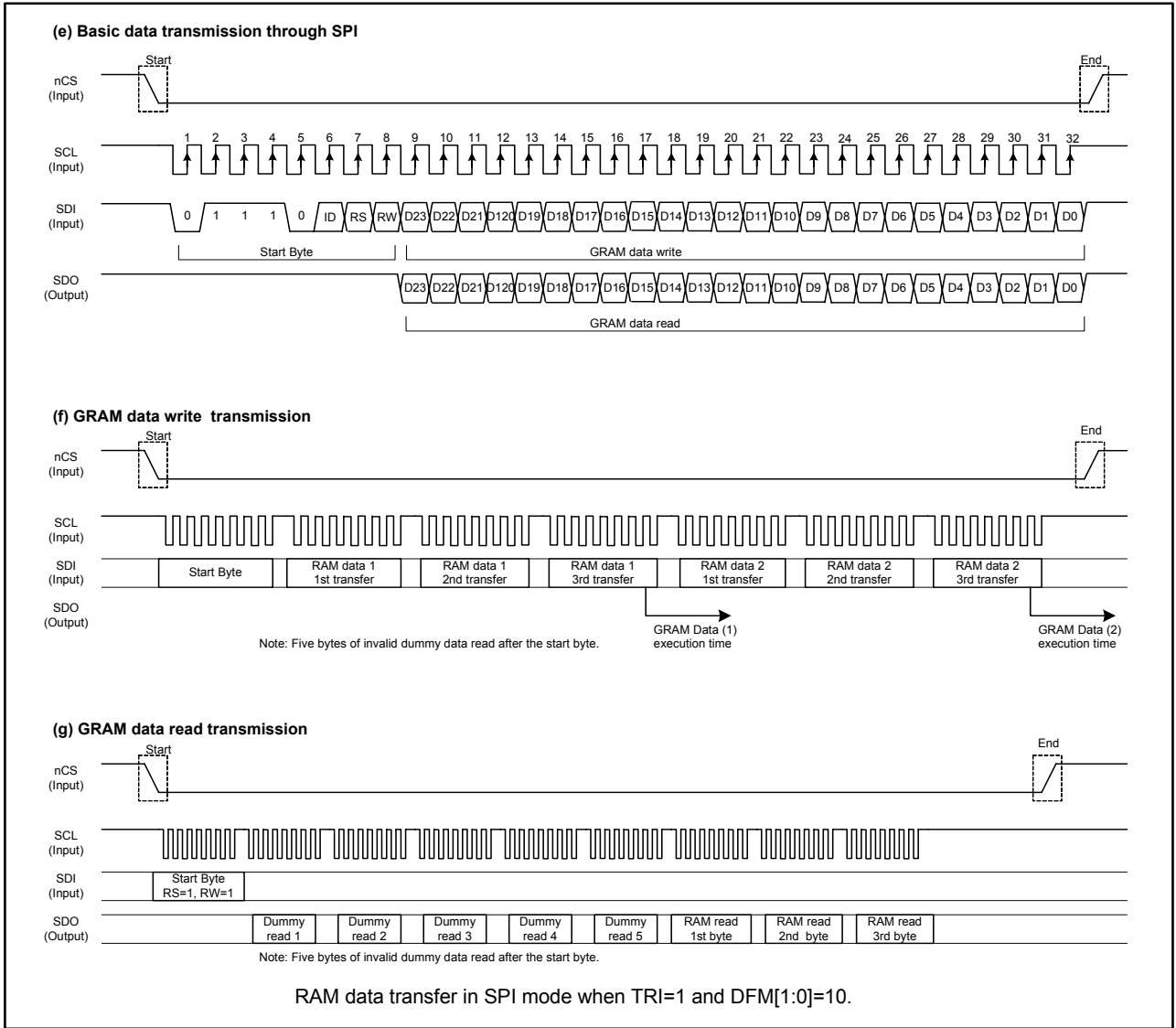

Figure9 Data transmission through serial peripheral interface (SPI), TRI="1" and DFM="10"

7.4. VSYNC Interface

ILI9325 supports the VSYNC interface in synchronization with the frame-synchronizing signal VSYNC to display the moving picture with the i80 system interface. When the VSYNC interface is selected to display a moving picture, the minimum GRAM update speed is limited and the VSYNC interface is enabled by setting DM[1:0] = "10" and RM = "0".

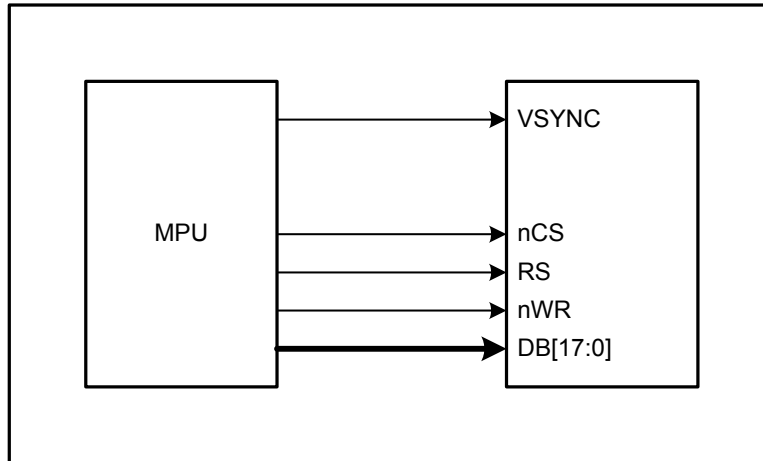

Figure10 Data transmission through VSYNC interface)

In the VSYNC mode, the display operation is synchronized with the internal clock and VSYNC input and the frame rate is determined by the pulse rate of VSYNC signal. All display data are stored in GRAM to minimize total data transfer required for moving picture display.

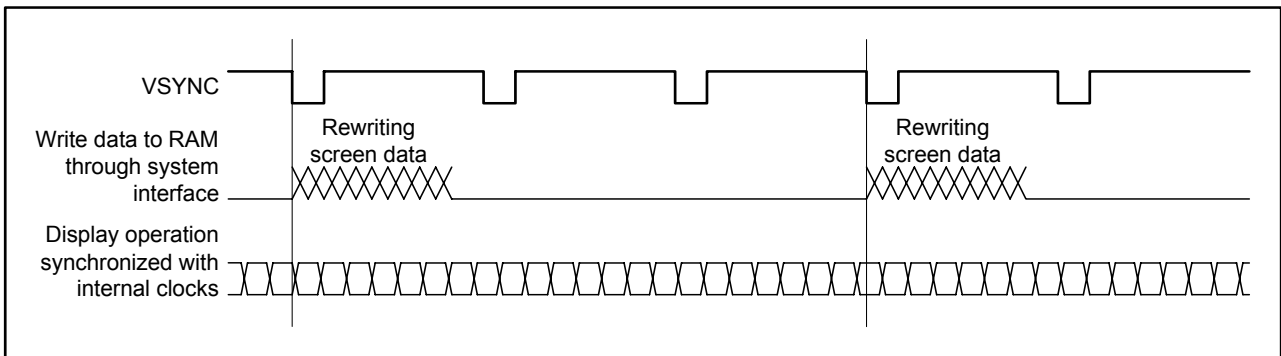

Figure11 Moving picture data transmission through VSYNC interface

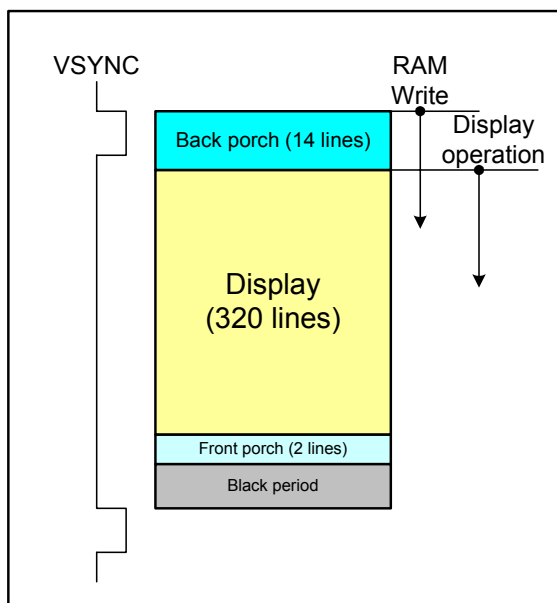

Figure12 Operation through VSYNC Interface

The VSYNC interface has the minimum speed limitation of writing data to the internal GRAM via the system interface, which are calculated from the following formula.

Internal clock frequency (fosc.) [Hz] = FrameFrequency x (DisplayLine (NL) + FrontPorch (FP) + BackPorch (BP)) x ClockCyclePerLines (RTN) x FrequencyFluctuation.

$$\text{Minimum RAM write speed (HZ)} > \frac{320 \times \text{DisplayLines (NL)}}{[(\text{BackPorch(BP)} + \text{DisplayLines(NL)} - \text{margins}) \times 16 \text{ (clocks)} \times 1/\text{fosc}]}$$

Note: When the RAM write operation does not start from the falling edge of VSYNC, the time from the falling edge of VSYNC until the start of RAM write operation must also be taken into account.

An example of minimum GRAM writing speed and internal clock frequency in VSYNC interface mode is as below.

[Example]

Display size: 240 RGB × 320 lines

Lines: 320 lines (NL = 1000111)

Back porch: 14 lines (BP = 1110)

Front porch: 2 lines (FP = 0010)

Frame frequency: 60 Hz

Frequency fluctuation: 10%

$$\text{Internal oscillator clock (fosc.) [Hz]} = 60 \times [320 + 2 + 14] \times 16 \text{ clocks} \times (1.1/0.9) \doteq 394\text{KHz}$$

When calculate the internal clock frequency, the oscillator variation is needed to be taken into consideration. In the above example, the calculated internal clock frequency with $\pm 10\%$ margin variation is considered and ensures to complete the display operation within one VSYNC cycle. The causes of frequency variation come from fabrication process of LSI, room temperature, external resistors and VCI voltage variation.

$$\text{Minimum speed for RAM writing [Hz]} > 240 \times 320 \times 394K / [(14 + 320 - 2)\text{lines} \times 16\text{clocks}] \doteq 5.7 \text{ MHz}$$

The above theoretical value is calculated based on the premise that the ILI9325 starts to write data into the internal GRAM on the falling edge of VSYNC. There must at least be a margin of 2 lines between the physical display line and the GRAM line address where data writing operation is performed. The GRAM write speed of 5.7MHz or more will guarantee the completion of GRAM write operation before the ILI9325 starts to display the GRAM data on the screen and enable to rewrite the entire screen without flicker.

Notes in using the VSYNC interface

1. The minimum GRAM write speed must be satisfied and the frequency variation must be taken into consideration.
2. The display frame rate is determined by the VSYNC signal and the period of VSYNC must be longer than the scan period of an entire display.
3. When switching from the internal clock operation mode (DM[1:0] = "00") to the VSYNC interface mode or inversely, the switching starts from the next VSYNC cycle, i.e. after completing the display of the frame.
4. The partial display, vertical scroll, and interlaced scan functions are not available in VSYNC interface mode and set the AM bit to "0" to transfer display data.

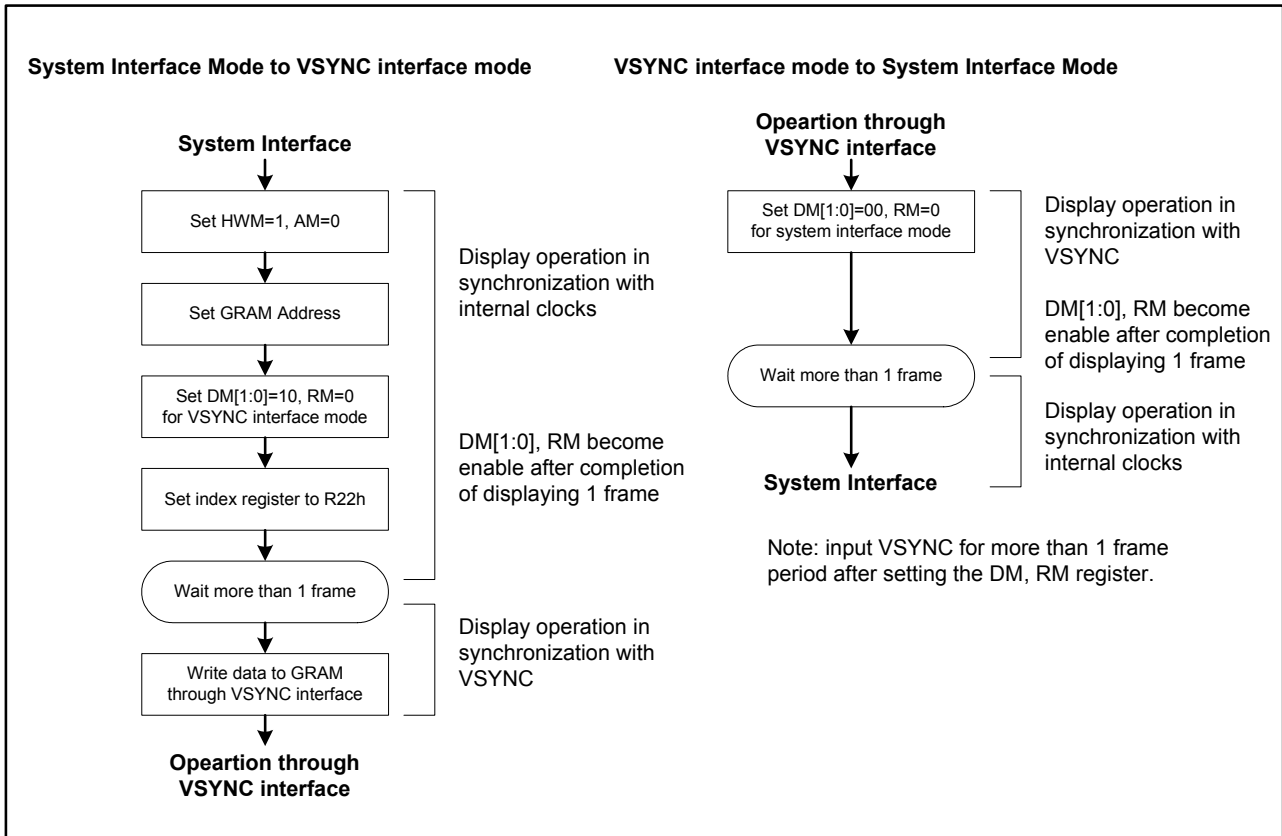

Figure13 Transition flow between VSYNC and internal clock operation modes

7.5. RGB Input Interface

The RGB Interface mode is available for ILI9325 and the interface is selected by setting the RIM[1:0] bits as following table.

RIM1	RIM0	RGB Interface	DB pins
0	0	18-bit RGB Interface	DB[17:0]
0	1	16-bit RGB Interface	DB[17:13], DB[11:1]
1	0	6-bit RGB Interface	DB[17:12]
1	1	Setting prohibited	

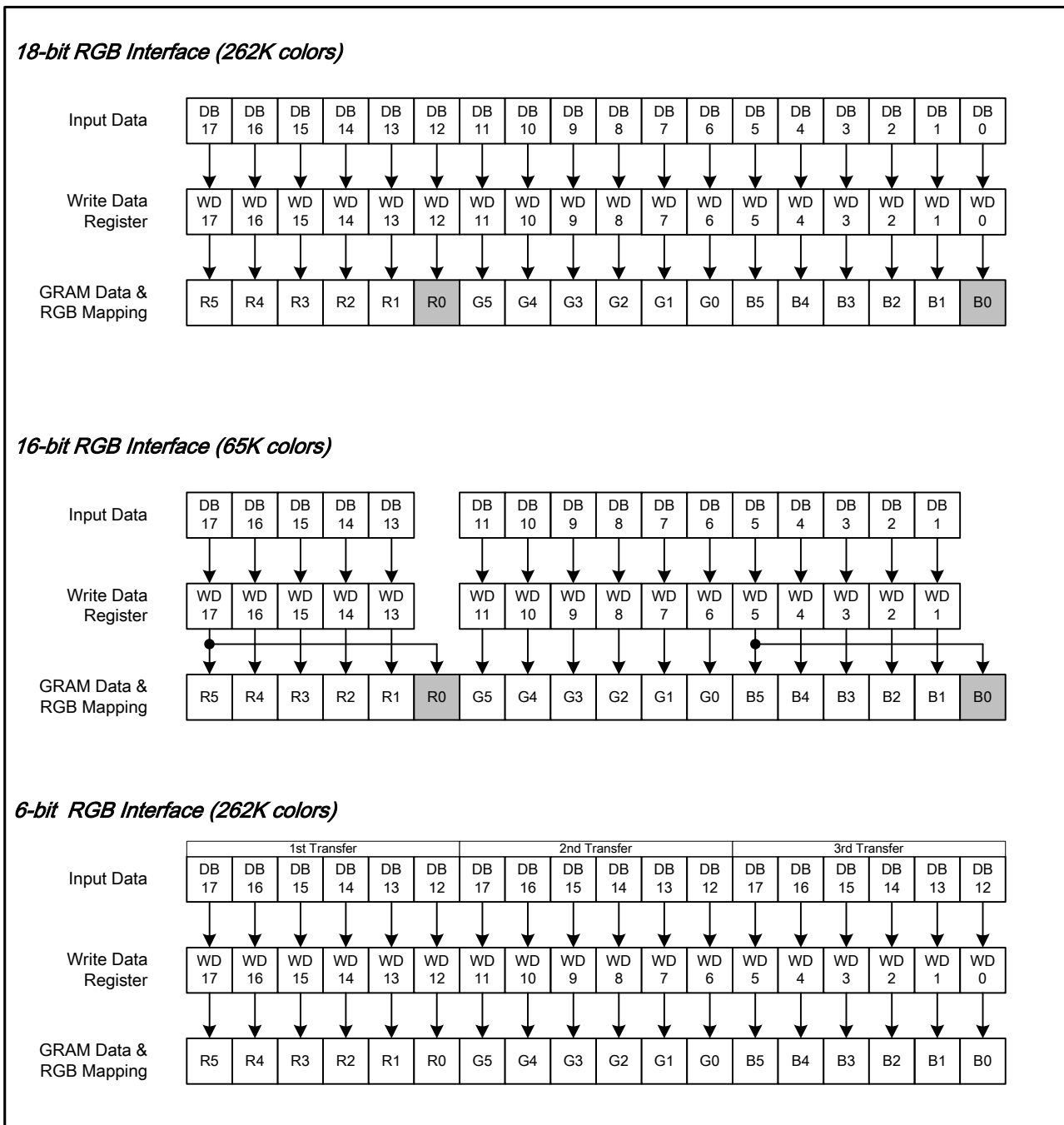

Figure14 RGB Interface Data Format

7.5.1. RGB Interface

The display operation via the RGB interface is synchronized with the VSYNC, HSYNC, and DOTCLK signals. The RGB interface transfers the updated data to GRAM with the high-speed write function and the update area is defined by the window address function. The back porch and front porch are used to set the RGB interface timing.

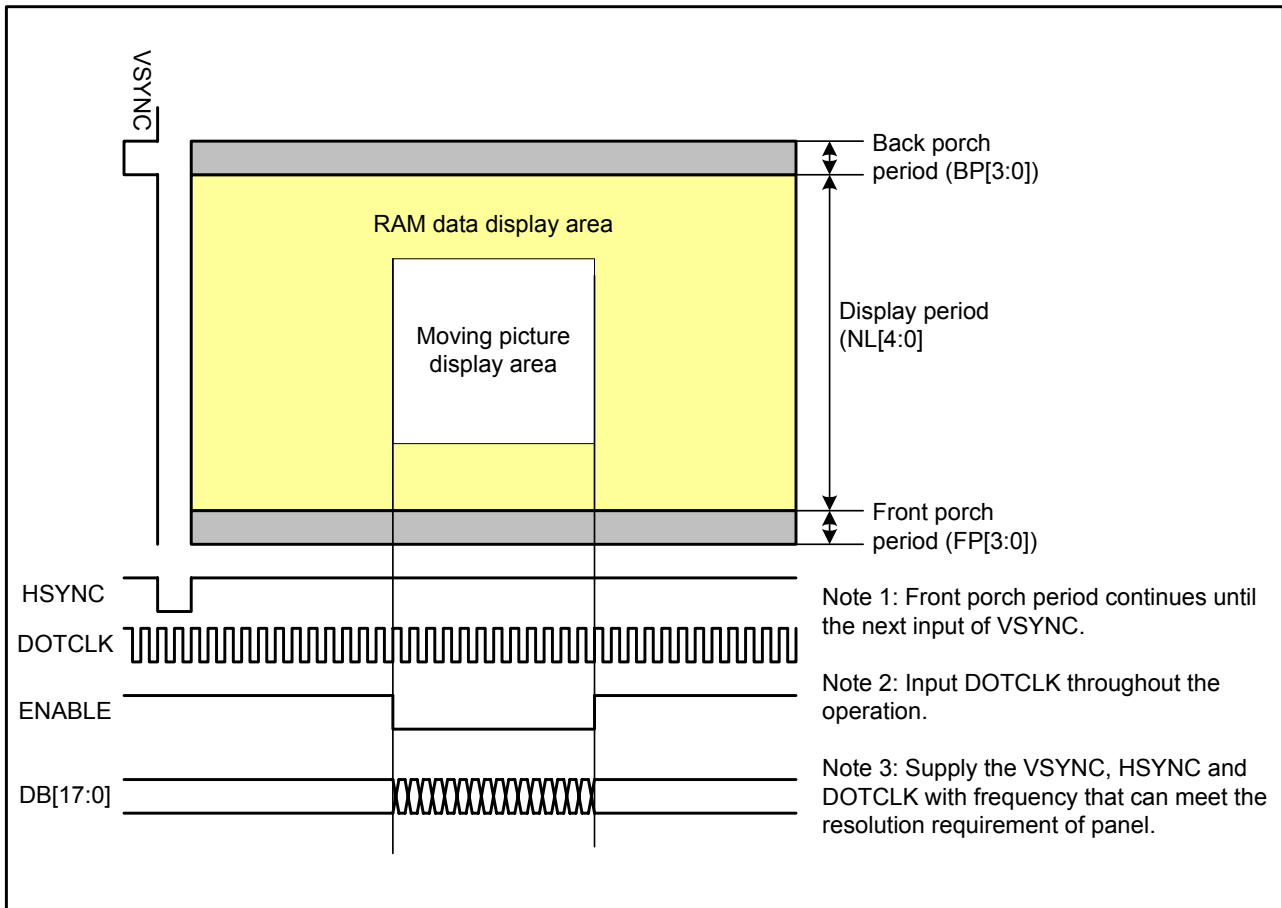

Figure15 GRAM Access Area by RGB Interface

7.5.2. RGB Interface Timing

The timing chart of 18-/16-bit RGB interface mode is shown as follows.

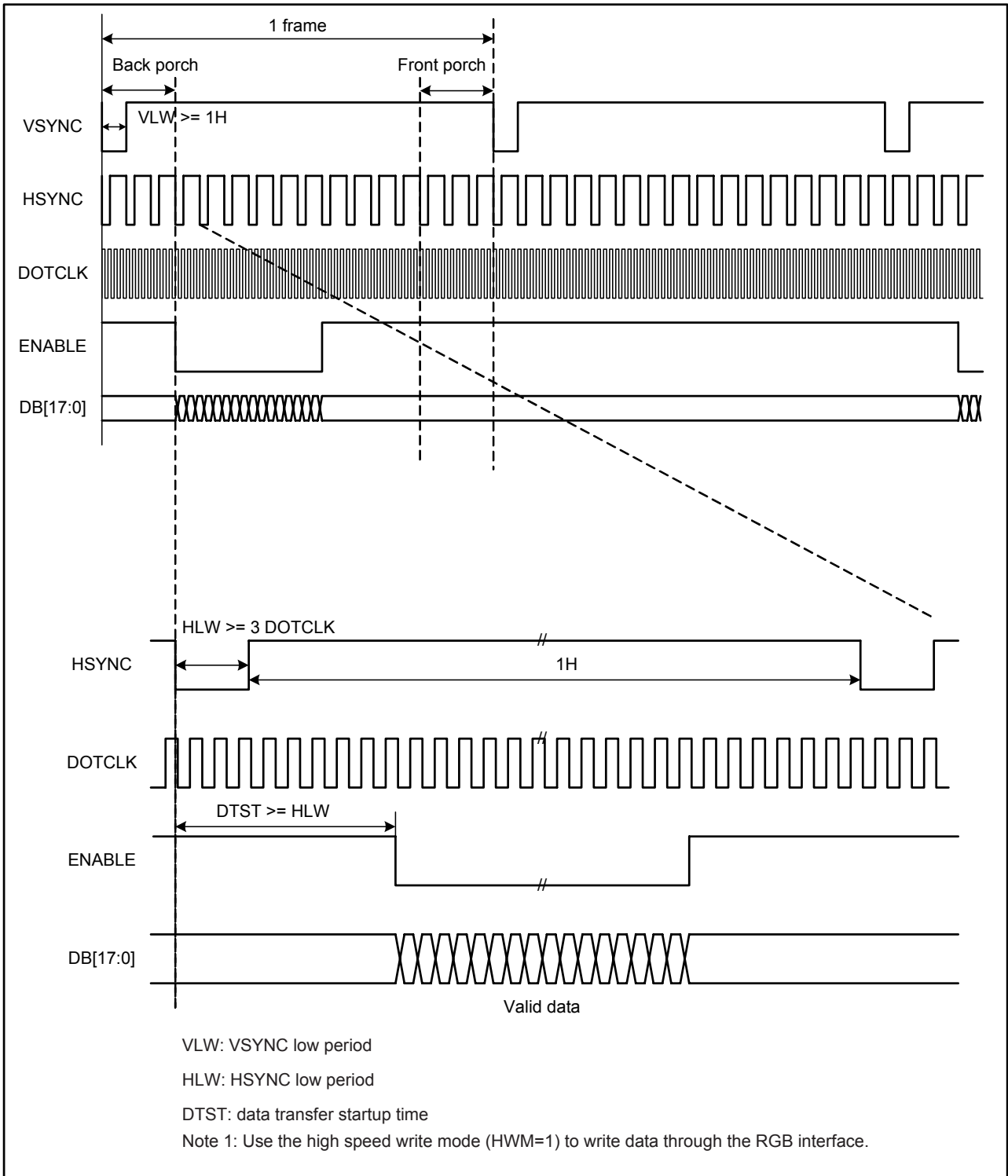

Figure16 Timing Chart of Signals in 18-/16-bit RGB Interface Mode

The timing chart of 6-bit RGB interface mode is shown as follows.

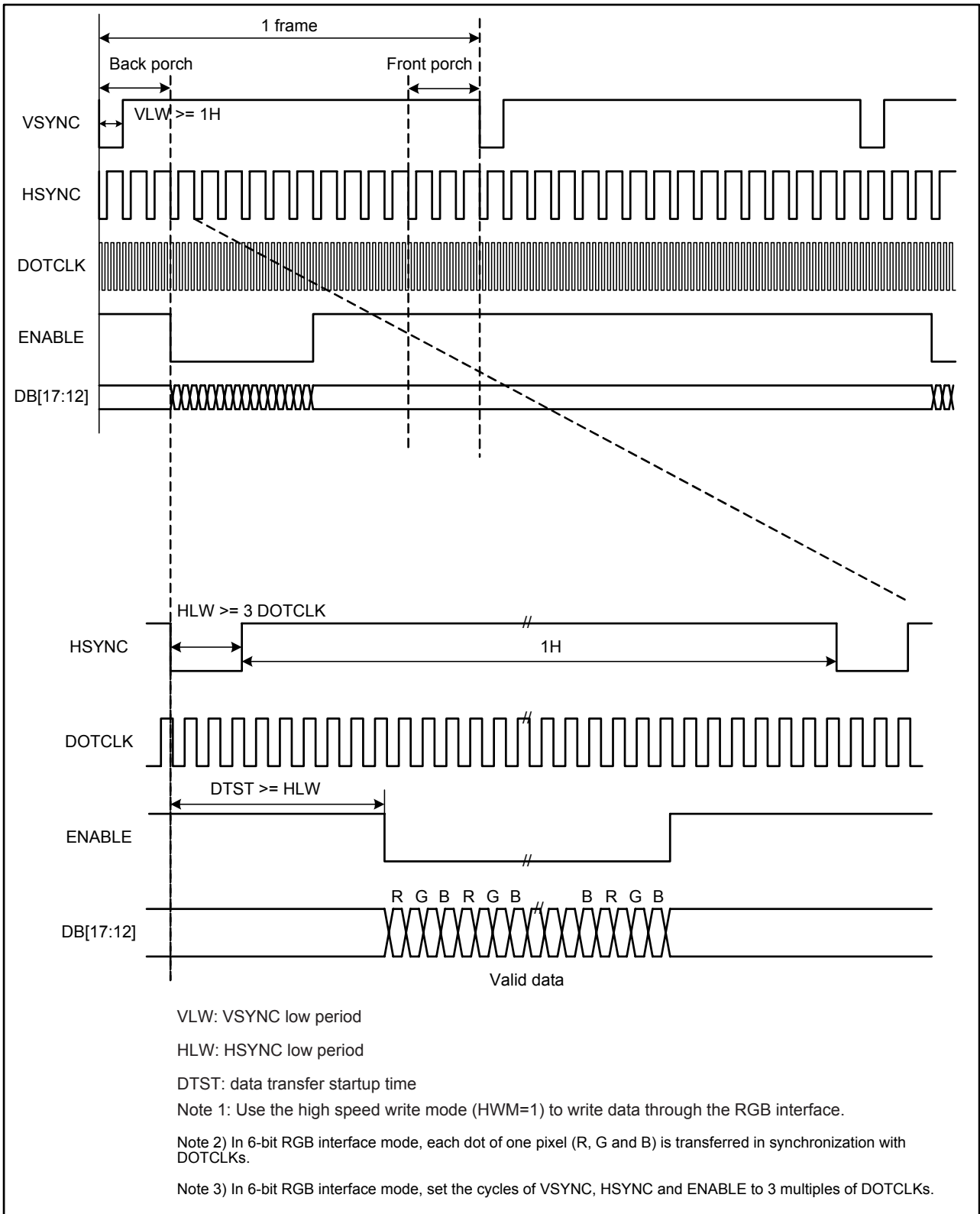

Figure17 Timing chart of signals in 6-bit RGB interface mode

7.5.3. Moving Picture Mode

ILI9325 has the RGB interface to display moving picture and incorporates GRAM to store display data, which has following merits in displaying a moving picture.

- The window address function defined the update area of GRAM.
- Only the moving picture area of GRAM is updated.
- When display the moving picture in RGB interface mode, the DB[17:0] can be switched as system interface to update still picture area and registers, such as icons.

RAM access via a system interface in RGB-I/F mode

ILI9325 allows GRAM access via the system interface in RGB interface mode. In RGB interface mode, data are written to the internal GRAM in synchronization with DOTCLK and ENABLE signals. When write data to the internal GRAM by the system interface, set ENABLE to terminate the RGB interface and switch to the system interface to update the registers (RM = "0") and the still picture of GRAM. When restart RAM access in RGB interface mode, wait one read/write cycle and then set RM = "1" and the index register to R22h to start accessing RAM via the RGB interface. If RAM accesses via two interfaces conflicts, there is no guarantee that data are written to the internal GRAM.

The following figure illustrates the operation of the ILI9325 when displaying a moving picture via the RGB interface and rewriting the still picture RAM area via the system interface.

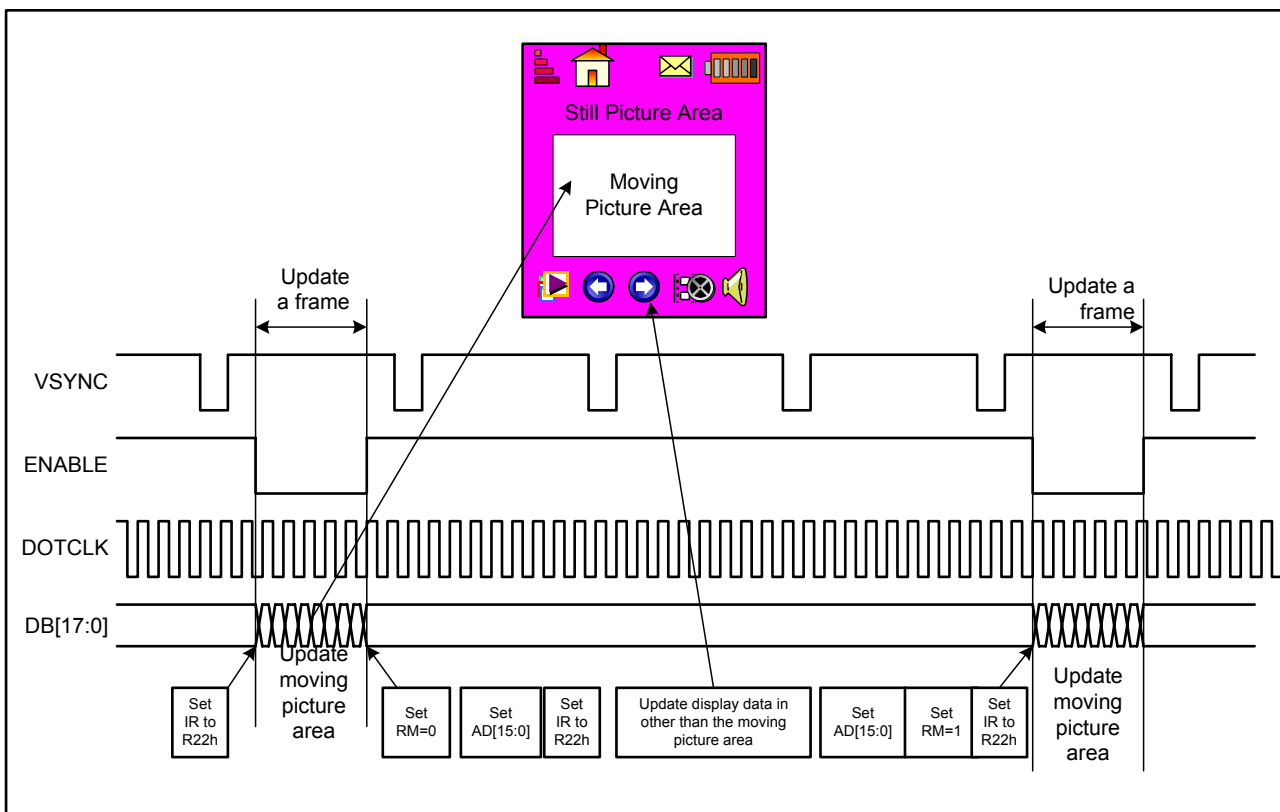
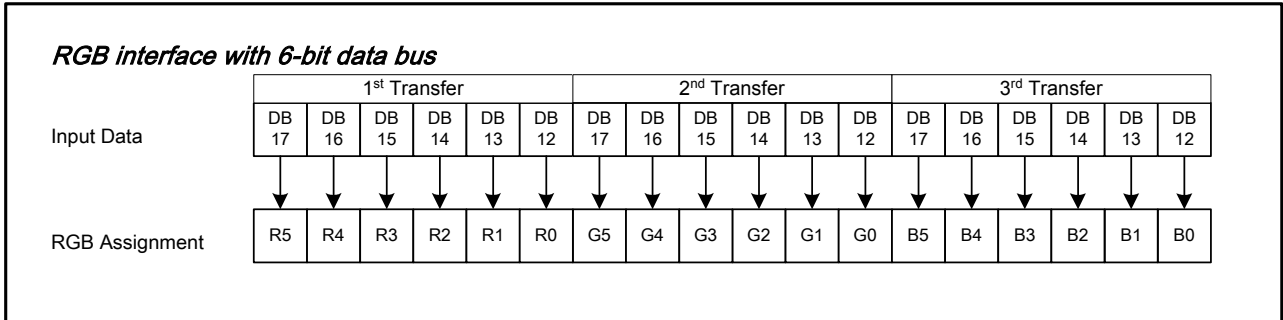

Figure18 Example of update the still and moving picture

7.5.4. 6-bit RGB Interface

The 6-bit RGB interface is selected by setting the RIM[1:0] bits to “10”. The display operation is synchronized with VSYNC, HSYNC, and DOTCLK signals. Display data are transferred to the internal GRAM in synchronization with the display operation via 6-bit RGB data bus (DB[17:12]) according to the data enable signal (ENABLE). Unused pins (DB[11:0]) must be fixed at GND level. Registers can be set by the system interface (i80/SPI).



Data transfer synchronization in 6-bit RGB interface mode

ILI9325 has data transfer counters to count the first, second, third data transfers in 6-bit RGB interface mode. The transfer counter is always reset to the state of first data transfer on the falling edge of VSYNC. If a mismatch arises in the number of each data transfer, the counter is reset to the state of first data transfer at the start of the frame (i.e. on the falling edge of VSYNC) to restart data transfer in the correct order from the next frame. This function is expedient for moving picture display, which requires consecutive data transfer in light of minimizing effects from failed data transfer and enabling the system to return to a normal state.

Note that internal display operation is performed in units of pixels (RGB: taking 3 inputs of DOTCLK). Accordingly, the number of DOTCLK inputs in one frame period must be a multiple of 3 to complete data transfer correctly. Otherwise it will affect the display of that frame as well as the next frame.

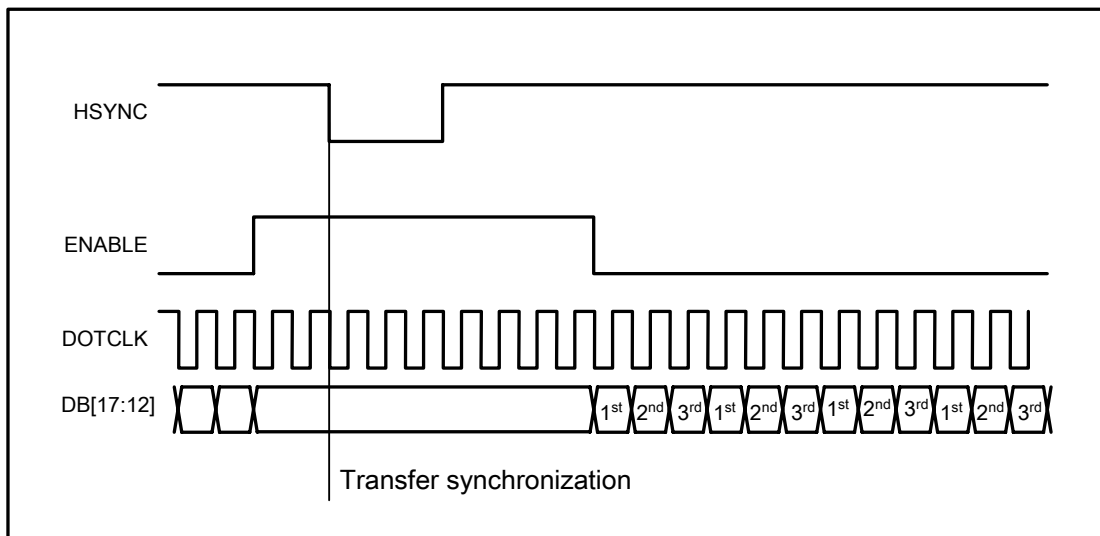

7.5.5. 16-bit RGB Interface

The 16-bit RGB interface is selected by setting the RIM[1:0] bits to "01". The display operation is synchronized with VSYNC, HSYNC, and DOTCLK signals. Display data are transferred to the internal RAM in synchronization with the display operation via 16-bit RGB data bus (DB17-13, DB11-1) according to the data enable signal (ENABLE). Registers are set only via the system interface.

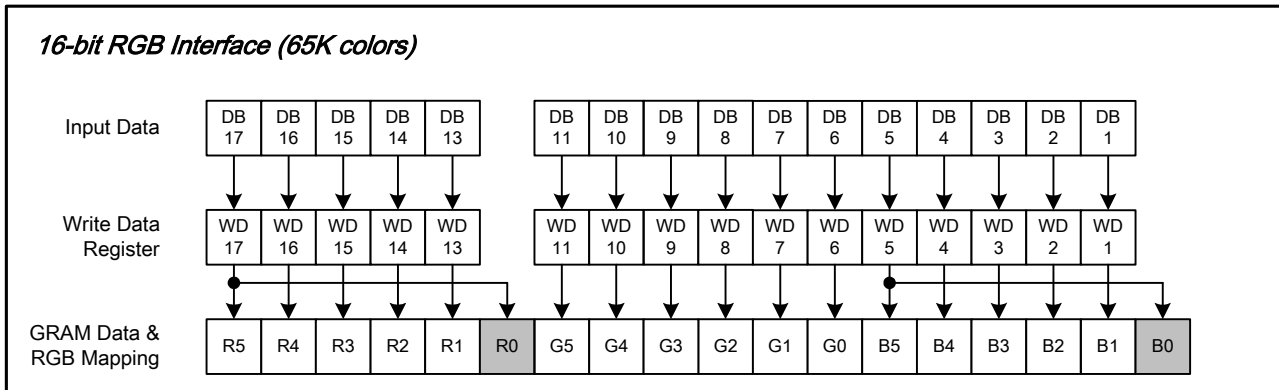

7.5.6. 18-bit RGB Interface

The 18-bit RGB interface is selected by setting the RIM[1:0] bits to "00". The display operation is synchronized with VSYNC, HSYNC, and DOTCLK signals. Display data are transferred to the internal RAM in synchronization with the display operation via 18-bit RGB data bus (DB[17:0]) according to the data enable signal (ENABLE). Registers are set only via the system interface.

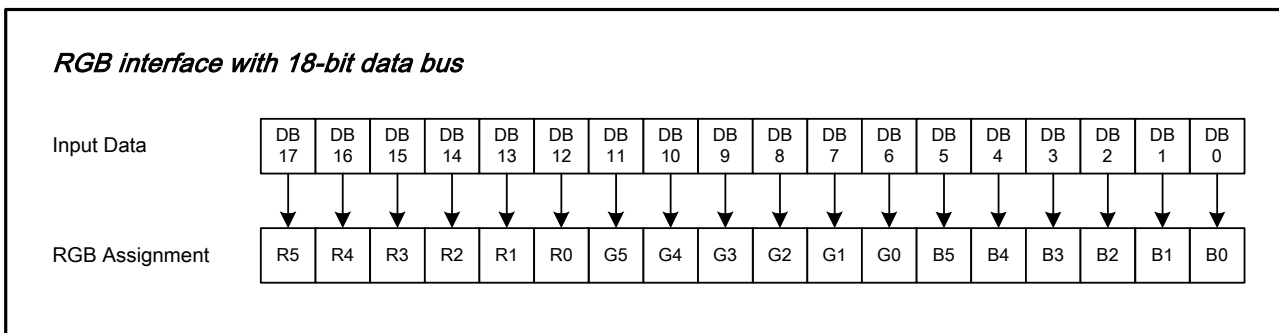

Notes in using the RGB Input Interface

1. The following are the functions not available in RGB Input Interface mode.

Function	RGB interface	I80 system interface
Partial display	Not available	Available
Scroll function	Not available	Available
Interlaced scan	Not available	Available
Graphics operation function	Not available	Available

2. VSYNC, HSYNC, and DOTCLK signals must be supplied throughout a display operation period.
3. The periods set with the NO[1:0] bits (gate output non-overlap period), STD[1:0] bits (source output delay period) and EQ[1:0] bits (equalization period) are not based on the internal clock but based on DOTCLK in

The information contained herein is the exclusive property of ILI Technology Corp. and shall not be distributed, reproduced, or disclosed in whole or in part without prior written permission of ILI Technology Corp.

- RGB interface mode.
4. In 6-bit RGB interface mode, each of RGB dots is transferred in synchronization with a DOTCLK input. In other words, it takes 3 DOTCLK inputs to transfer one pixel. Be sure to complete data transfer in units of 3 DOTCLK inputs in 6-bit RGB interface mode.
 5. In 6-bit RGB interface mode, data of one pixel, which consists of RGB dots, are transferred in units of 3 DOTCLK. Accordingly, set the cycle of each signal in 6-bit interface mode (VSYNC, HSYNC, ENABLE, DB[17:0]) to contain DOTCLK inputs of a multiple of 3 to complete data transfer in units of pixels.
 6. When switching from the internal operation mode to the RGB Input Interface mode, or the other way around, follow the sequence below.
 7. In RGB interface mode, the front porch period continues until the next VSYNC input is detected after drawing one frame.
 8. In RGB interface mode, a RAM address (AD[15:0]) is set in the address counter every frame on the falling edge of VSYNC.

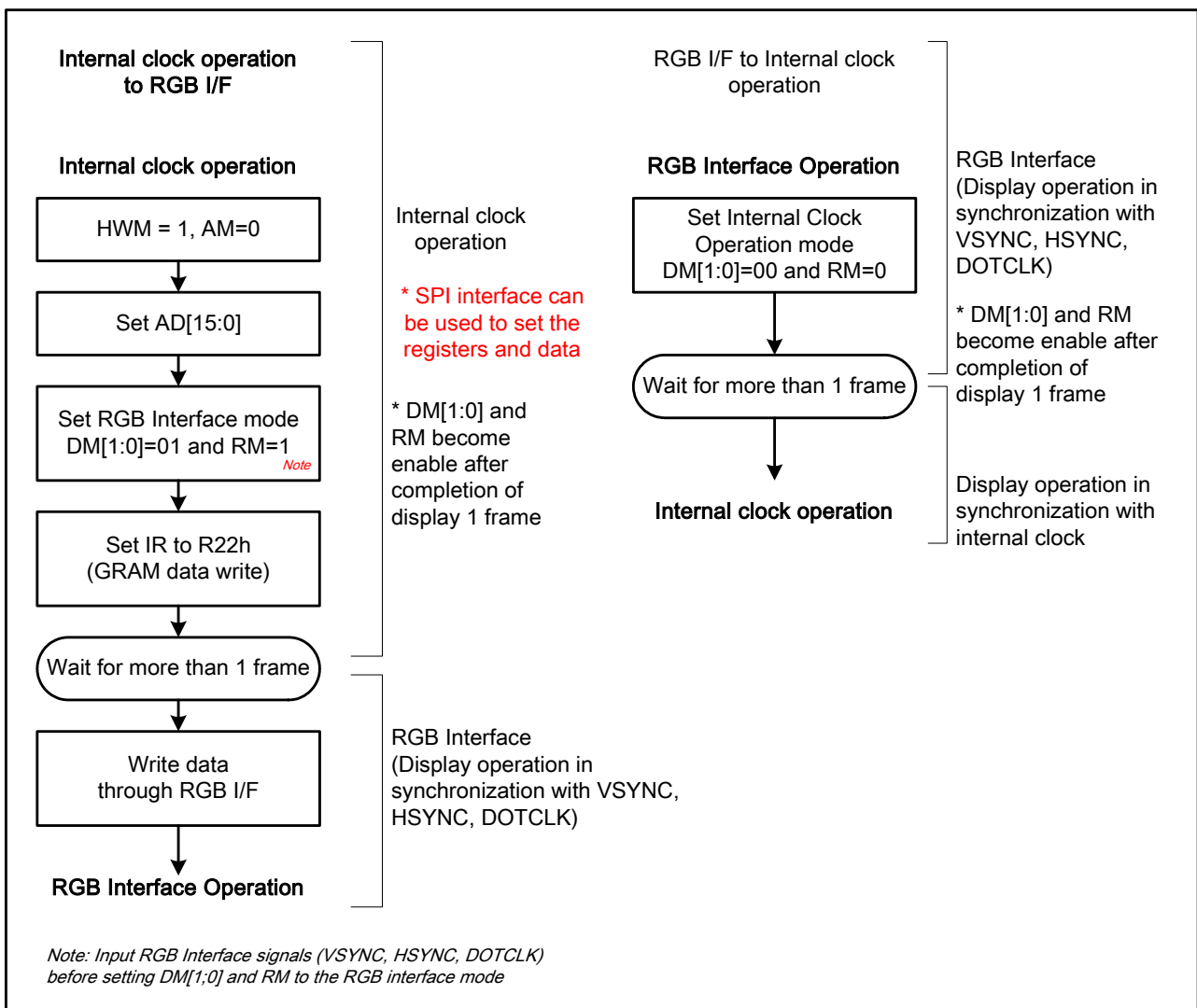

Figure19 Internal clock operation/RGB interface mode switching

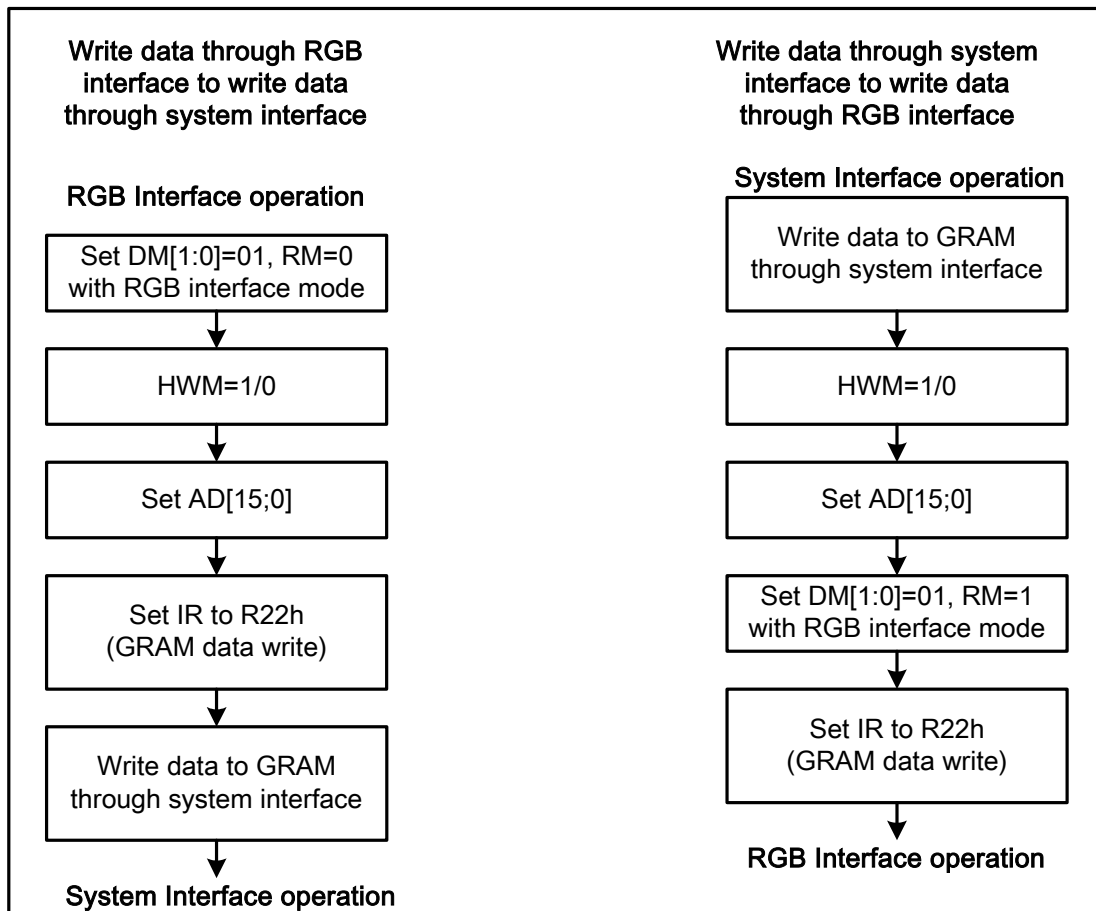

Figure20 GRAM access between system interface and RGB interface

7.6. Interface Timing

The following are diagrams of interfacing timing with LCD panel control signals in internal operation and RGB interface modes.

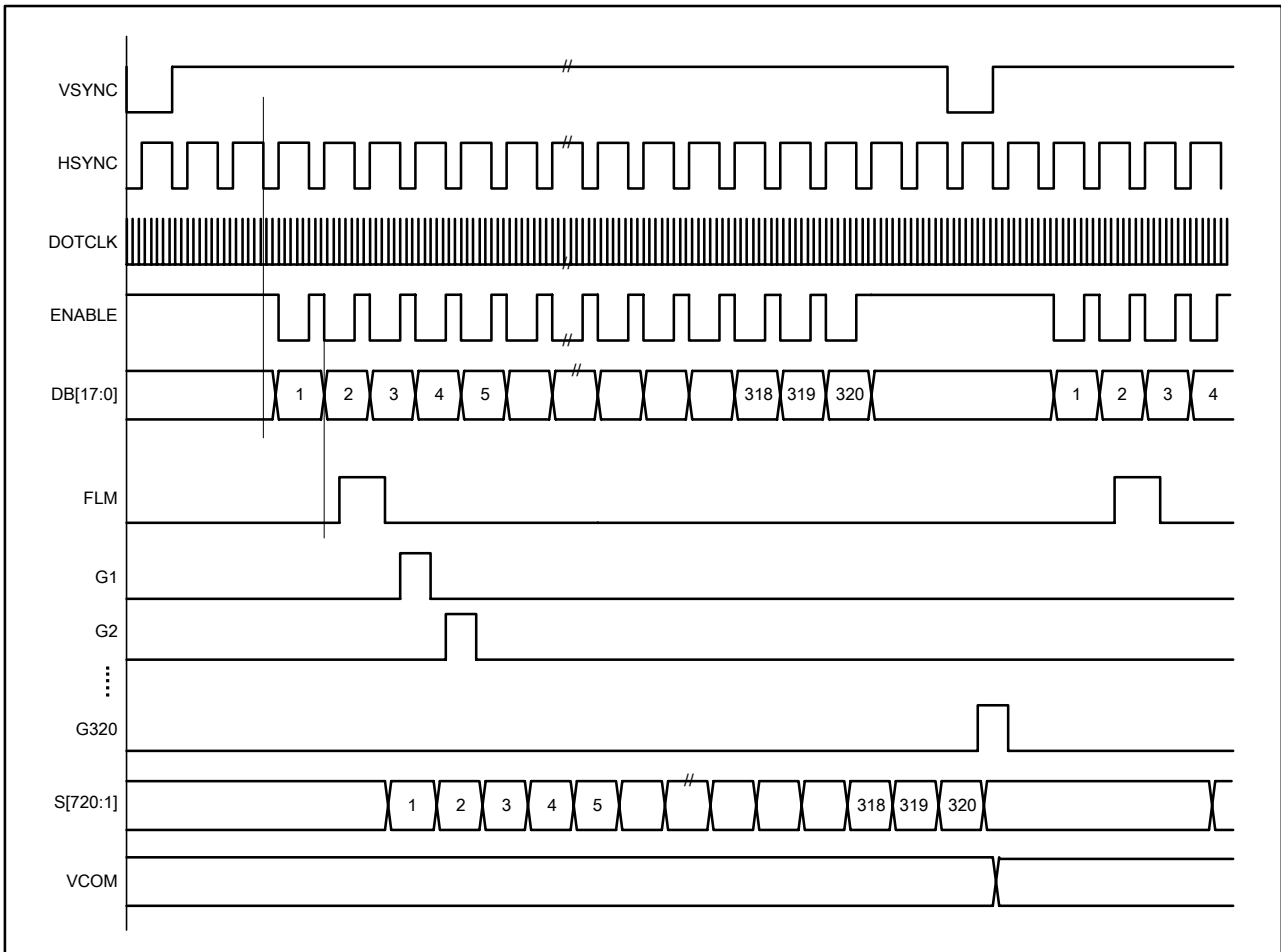

Figure21 Relationship between RGB I/F signals and LCD Driving Signals for Panel

8. Register Descriptions

8.1. Registers Access

ILI9325 adopts 18-bit bus interface architecture for high-performance microprocessor. All the functional blocks of ILI9325 starts to work after receiving the correct instruction from the external microprocessor by the 18-, 16-, 9-, 8-bit interface. The index register (IR) stores the register address to which the instructions and display data will be written. The register selection signal (RS), the read/write signals (nRD/nWR) and data bus D17-0 are used to read/write the instructions and data of ILI9325. The registers of the ILI9325 are categorized into the following groups.

1. Specify the index of register (IR)
2. Read a status
3. Display control
4. Power management Control
5. Graphics data processing
6. Set internal GRAM address (AC)
7. Transfer data to/from the internal GRAM (R22)
8. Internal grayscale γ -correction (R30 ~ R39)

Normally, the display data (GRAM) is most often updated, and in order since the ILI9325 can update internal GRAM address automatically as it writes data to the internal GRAM and minimize data transfer by using the window address function, there are fewer loads on the program in the microprocessor. As the following figure shows, the way of assigning data to the 16 register bits (D[15:0]) varies for each interface. Send registers in accordance with the following data transfer format.

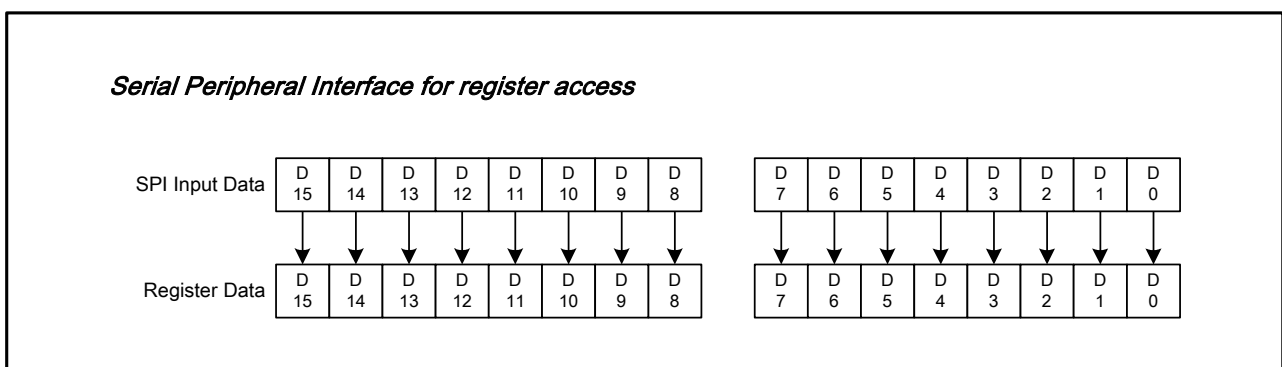
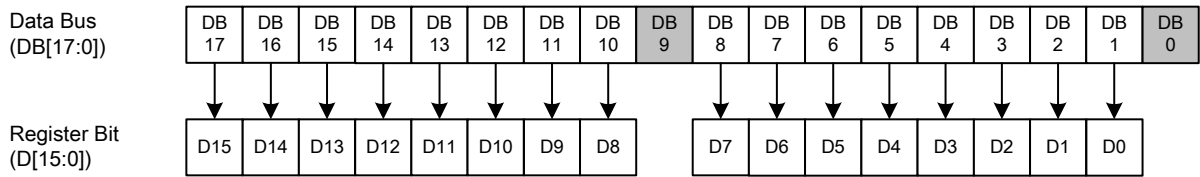
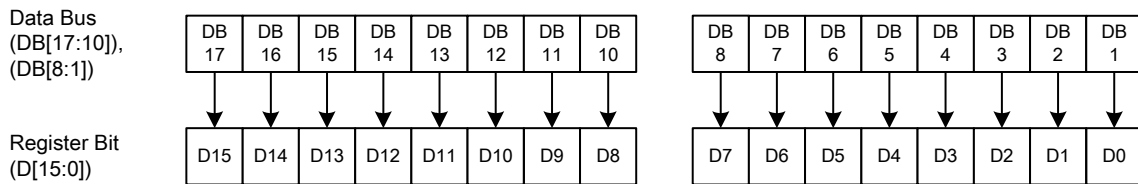

Figure22 Register Setting with Serial Peripheral Interface (SPI)

i80/M68 system 18-bit data bus interface



i80/M68 system 16-bit data bus interface



i80/M68 system 9-bit data bus interface

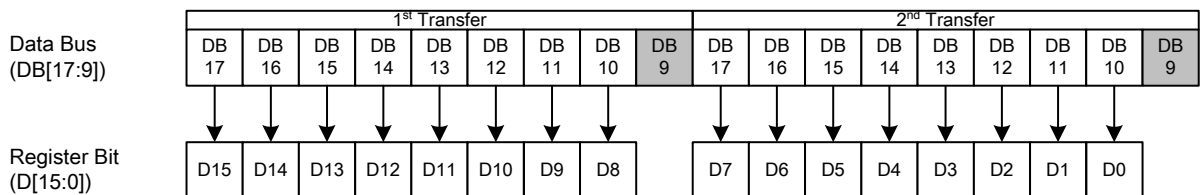

i80/M68 system 8-bit data bus interface/Serial peripheral interface (2/3 transmission)

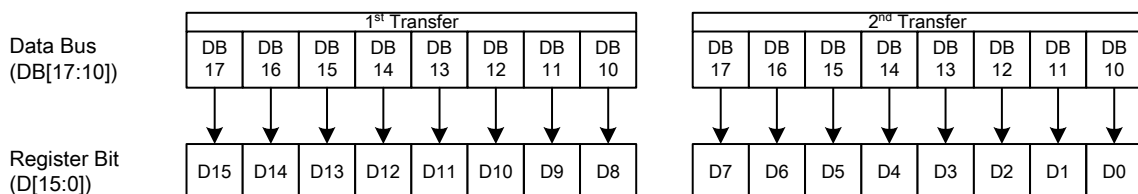

Figure23 Register setting with i80 System Interface

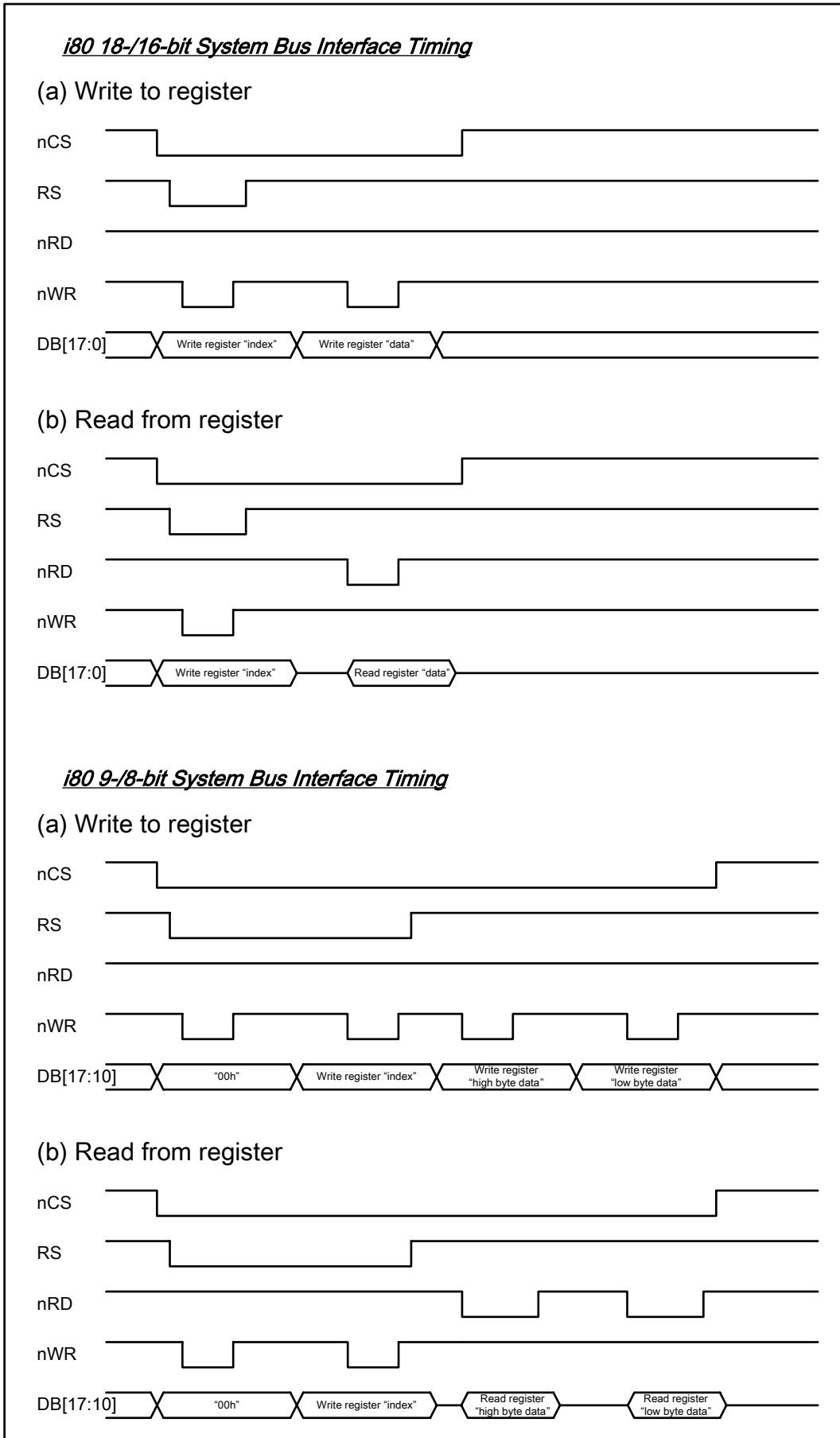

Figure 24 Register Read/Write Timing of i80 System Interface

8.2. Instruction Descriptions

No.	Registers Name	R/W	RS	D15	D14	D13	D12	D11	D10	D9	D8	D7	D6	D5	D4	D3	D2	D1	D0
IR	Index Register	W	0	-	-	-	-	-	-	-	-	ID7	ID6	ID5	ID4	ID3	ID2	ID1	ID0
00h	Driver Code Read	R	1	1	0	0	1	0	0	1	1	0	0	1	0	0	1	0	1
01h	Driver Output Control 1	W	1	0	0	0	0	0	SM	0	SS	0	0	0	0	0	0	0	0
02h	LCD Driving Control	W	1	0	0	0	0	0	0	BC0	EOR	0	0	0	0	0	0	0	0
03h	Entry Mode	W	1	TRI	DFM	0	BGR	0	0	HWM	0	ORG	0	I/D1	I/D0	AM	0	0	0
04h	Resize Control	W	1	0	0	0	0	0	0	RCV1	RCV0	0	0	RCH1	RCH0	0	0	RSZ1	RSZ0
07h	Display Control 1	W	1	0	0	PTDE1	PTDE0	0	0	0	BASEE	0	0	GON	DTE	CL	0	D1	D0
08h	Display Control 2	W	1	0	0	0	0	FP3	FP2	FP1	FP0	0	0	0	0	BP3	BP2	BP1	BP0
09h	Display Control 3	W	1	0	0	0	0	0	PTS2	PTS1	PTS0	0	0	PTG1	PTG0	ISC3	ISC2	ISC1	ISC0
0Ah	Display Control 4	W	1	0	0	0	0	0	0	0	0	0	0	0	0	FMARKOE	FMI2	FMI1	FMI0
0Ch	RGB Display Interface Control 1	W	1	0	ENC2	ENC1	ENC0	0	0	0	RM	0	0	DM1	DM0	0	0	RIM1	RIM0
0Dh	Frame Maker Position	W	1	0	0	0	0	0	0	0	FMP8	FMP7	FMP6	FMP5	FMP4	FMP3	FMP2	FMP1	FMP0
0Fh	RGB Display Interface Control 2	W	1	0	0	0	0	0	0	0	0	0	0	0	VSPL	HSPL	0	DPL	EPL
10h	Power Control 1	W	1	0	0	0	SAP	0	BT2	BT1	BT0	APE	AP2	AP1	AP0	0	DSTB	SLP	STB
11h	Power Control 2	W	1	0	0	0	0	0	DC12	DC11	DC10	0	DC02	DC01	DC00	0	VC2	VC1	VC0
12h	Power Control 3	W	1	0	0	0	0	0	0	0	0	VCIRE	0	0	PON	VRH3	VRH2	VRH1	VRH0
13h	Power Control 4	W	1	0	0	0	VDV4	VDV3	VDV2	VDV1	VDV0	0	0	0	0	0	0	0	0
20h	Horizontal GRAM Address Set	W	1	0	0	0	0	0	0	0	0	AD7	AD6	AD5	AD4	AD3	AD2	AD1	AD0
21h	Vertical GRAM Address Set	W	1	0	0	0	0	0	0	0	AD16	AD15	AD14	AD13	AD12	AD11	AD10	AD9	AD8
22h	Write Data to GRAM	W	1	RAM write data (WD17-0) / read data (RD17-0) bits are transferred via different data bus lines according to the selected interfaces.															
29h	Power Control 7	W	1	0	0	0	0	0	0	0	0	0	0	VCM5	VCM4	VCM3	VCM2	VCM1	VCM0
2Bh	Frame Rate and Color Control	W	1	0	0	0	0	0	0	0	0	0	0	0	0	FRS[3]	FRS[2]	FRS[1]	FRS[0]
30h	Gamma Control 1	W	1	0	0	0	0	0	KP1[2]	KP1[1]	KP1[0]	0	0	0	0	0	KP0[2]	KP0[1]	KP0[0]
31h	Gamma Control 2	W	1	0	0	0	0	0	KP3[2]	KP3[1]	KP3[0]	0	0	0	0	0	KP2[2]	KP2[1]	KP2[0]
32h	Gamma Control 3	W	1	0	0	0	0	0	KP5[2]	KP5[1]	KP5[0]	0	0	0	0	0	KP4[2]	KP4[1]	KP4[0]
35h	Gamma Control 4	W	1	0	0	0	0	0	RP1[2]	RP1[1]	RP1[0]	0	0	0	0	0	RP0[2]	RP0[1]	RP0[0]
36h	Gamma Control 5	W	1	0	0	0	VRP1[4]	VRP1[3]	VRP1[2]	VRP1[1]	VRP1[0]	0	0	0	0	VRP0[3]	VRP0[2]	VRP0[1]	VRP0[0]
37h	Gamma Control 6	W	1	0	0	0	0	0	KN1[2]	KN1[1]	KN1[0]	0	0	0	0	0	KN0[2]	KN0[1]	KN0[0]
38h	Gamma Control 7	W	1	0	0	0	0	0	KN3[2]	KN3[1]	KN3[0]	0	0	0	0	0	KN2[2]	KN2[1]	KN2[0]
39h	Gamma Control 8	W	1	0	0	0	0	0	KN5[2]	KN5[1]	KN5[0]	0	0	0	0	0	KN4[2]	KN4[1]	KN4[0]
3Ch	Gamma Control 9	W	1	0	0	0	0	0	RN1[2]	RN1[1]	RN1[0]	0	0	0	0	0	RN0[2]	RN0[1]	RN0[0]
3Dh	Gamma Control 10	W	1	0	0	0	VRN1[4]	VRN1[3]	VRN1[2]	VRN1[1]	VRN1[0]	0	0	0	0	VRN0[3]	VRN0[2]	VRN0[1]	VRN0[0]
50h	Horizontal Address Start	W	1	0	0	0	0	0	0	0	0	HSA7	HSA6	HSA5	HSA4	HSA3	HSA2	HSA1	HSA0

The information contained herein is the exclusive property of ILI Technology Corp. and shall not be distributed, reproduced, or disclosed in whole or in part without prior written permission of ILI Technology Corp.

No.	Registers Name	R/W	RS	D15	D14	D13	D12	D11	D10	D9	D8	D7	D6	D5	D4	D3	D2	D1	D0
	Position																		
51h	Horizontal Address End Position	W	1	0	0	0	0	0	0	0	0	HEA7	HEA6	HEA5	HEA4	HEA3	HEA2	HEA1	HEA0
52h	Vertical Address Start Position	W	1	0	0	0	0	0	0	0	VSA8	VSA7	VSA6	VSA5	VSA4	VSA3	VSA2	VSA1	VSA0
53h	Vertical Address End Position	W	1	0	0	0	0	0	0	0	VEA8	VEA7	VEA6	VEA5	VEA4	VEA3	VEA2	VEA1	VEA0
60h	Driver Output Control 2	W	1	GS	0	NL5	NL4	NL3	NL2	NL1	NL0	0	0	SCN5	SCN4	SCN3	SCN2	SCN1	SCN0
61h	Base Image Display Control	W	1	0	0	0	0	0	0	0	0	0	0	0	0	0	NDL	VLE	REV
6Ah	Vertical Scroll Control	W	1	0	0	0	0	0	0	0	VL8	VL7	VL6	VL5	VL4	VL3	VL2	VL1	VL0
80h	Partial Image 1 Display Position	W	1	0	0	0	0	0	0	0	PTDP08	PTDP07	PTDP06	PTDP05	PTDP04	PTDP03	PTDP02	PTDP01	PTDP00
81h	Partial Image 1 Area (Start Line)	W	1	0	0	0	0	0	0	0	PTSA08	PTSA07	PTSA06	PTSA05	PTSA04	PTSA03	PTSA02	PTSA01	PTSA00
82h	Partial Image 1 Area (End Line)	W	1	0	0	0	0	0	0	0	PTEA08	PTEA07	PTEA06	PTEA05	PTEA04	PTEA03	PTEA02	PTEA01	PTEA00
83h	Partial Image 2 Display Position	W	1	0	0	0	0	0	0	0	PTDP18	PTDP17	PTDP16	PTDP15	PTDP14	PTDP13	PTDP12	PTDP11	PTDP10
84h	Partial Image 2 Area (Start Line)	W	1	0	0	0	0	0	0	0	PTSA18	PTSA17	PTSA16	PTSA15	PTSA14	PTSA13	PTSA12	PTSA11	PTSA10
85h	Partial Image 2 Area (End Line)	W	1	0	0	0	0	0	0	0	PTEA18	PTEA17	PTEA16	PTEA15	PTEA14	PTEA13	PTEA12	PTEA11	PTEA10
90h	Panel Interface Control 1	W	1	0	0	0	0	0	0	DIV11	DIV10	0	0	0	0	RTNI3	RTNI2	RTNI1	RTNI0
92h	Panel Interface Control 2	W	1	0	0	0	0	0	NOW12	NOW11	NOW10	0	0	0	0	0	0	0	0
95h	Panel Interface Control 4	W	1	0	0	0	0	0	0	DIVE1	DIVE0	0	0	RTNE5	RTNE4	RTNE3	RTNE2	RTNE1	RTNE0
A1h	OTP VCM Programming Control	W	1	0	0	0	0	OTP_PGM_EN	0	0	0	0	0	VCM_OTP5	VCM_OTP4	VCM_OTP3	VCM_OTP2	VCM_OTP1	VCM_OTP0
A2h	OTP VCM Status and Enable	W	1	PGM_CNT1	PGM_CNT0	VCM_D5	VCM_D4	VCM_D3	VCM_D2	VCM_D1	VCM_D0	0	0	0	0	0	0	0	VCM_EN
A5h	OTP Programming ID Key	W	1	KEY 15	KEY 14	KEY 13	KEY 12	KEY 11	KEY 10	KEY 9	KEY 8	KEY 7	KEY 6	KEY 5	KEY 4	KEY 3	KEY 2	KEY 1	KEY 0

8.2.1. Index (IR)

R/W	RS	D15	D14	D13	D12	D11	D10	D9	D8	D7	D6	D5	D4	D3	D2	D1	D0
W	0	-	-	-	-	-	-	-	-	ID7	ID6	ID5	ID4	ID3	ID2	ID1	ID0

The index register specifies the address of register (R00h ~ RFFh) or RAM which will be accessed.

8.2.2. Start Oscillation (R00h)

R/W	RS	D15	D14	D13	D12	D11	D10	D9	D8	D7	D6	D5	D4	D3	D2	D1	D0
W	1	-	-	-	-	-	-	-	-	-	-	-	-	-	-	-	1
R	1	1	0	0	1	0	0	1	1	0	0	1	0	0	1	0	1

The device code "9325" is read out when read this register.

8.2.3. Driver Output Control (R01h)

R/W	RS	D15	D14	D13	D12	D11	D10	D9	D8	D7	D6	D5	D4	D3	D2	D1	D0
W	1	0	0	0	0	0	SM	0	SS	0	0	0	0	0	0	0	0

SS: Select the shift direction of outputs from the source driver.

When SS = 0, the shift direction of outputs is from S1 to S720

When SS = 1, the shift direction of outputs is from S720 to S1.

In addition to the shift direction, the settings for both SS and BGR bits are required to change the assignment of R, G, B dots to the source driver pins.

To assign R, G, B dots to the source driver pins from S1 to S720, set SS = 0.

To assign R, G, B dots to the source driver pins from S720 to S1, set SS = 1.

When changing SS or BGR bits, RAM data must be rewritten.

SM: Sets the gate driver pin arrangement in combination with the GS bit (R60h) to select the optimal scan mode for the module.

SM	GS	Scan Direction	Gate Output Sequence
0	0	<p>Even-number</p> <p>TFT Panel</p> <p>Odd-number</p> <p>G2 to G320</p> <p>G1 to G319</p> <p>ILI9325</p>	<p>G1, G2, G3, G4, ..., G316</p> <p>G317, G318, G319, G320</p>
0	1	<p>Even-number</p> <p>TFT Panel</p> <p>Odd-number</p> <p>G2 to G320</p> <p>G1 to G319</p> <p>ILI9325</p>	<p>G320, G319, G318, ...,</p> <p>G6, G5, G4, G3, G2, G1</p>
1	0	<p>Even-number</p> <p>TFT Panel</p> <p>Odd-number</p> <p>G2 to G320</p> <p>G1 to G319</p> <p>ILI9325</p>	<p>G1, G3, G5, G7, ..., G311</p> <p>G313, G315, G317, G319</p> <p>G2, G4, G6, G8, ..., G312</p> <p>G314, G316, G318, G320</p>

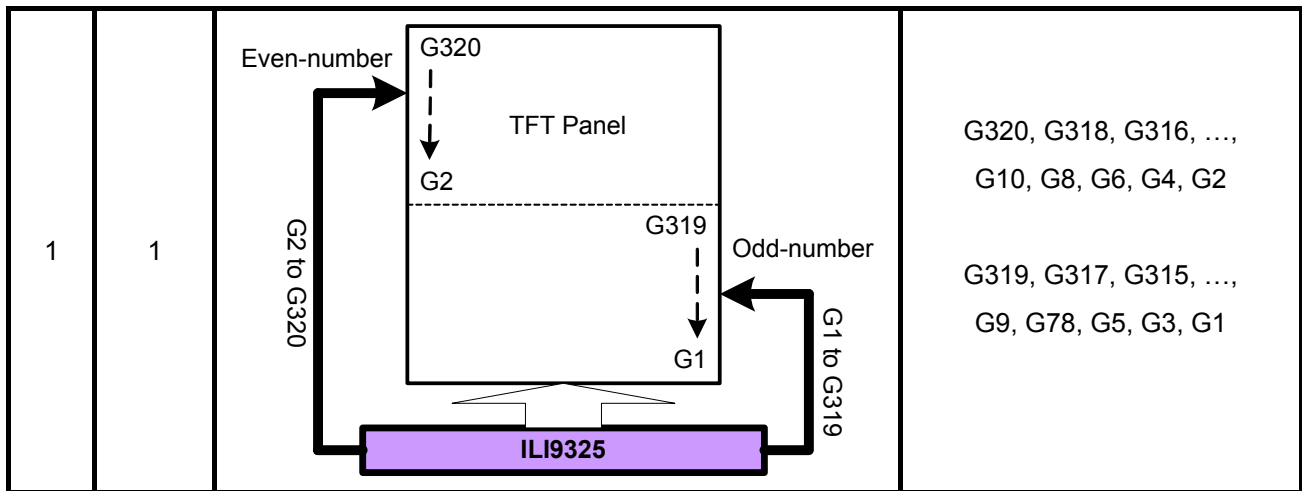

8.2.4. LCD Driving Wave Control (R02h)

R/W	RS	D15	D14	D13	D12	D11	D10	D9	D8	D7	D6	D5	D4	D3	D2	D1	D0
W	1	0	0	0	0	0	1	B/C	EOR	0	0	0	0	0	0	0	0

B/C 0 : Frame/Field inversion

1 : Line inversion

EOR: EOR = 1 and B/C=1 to set the line inversion.

8.2.5. Entry Mode (R03h)

R/W	RS	D15	D14	D13	D12	D11	D10	D9	D8	D7	D6	D5	D4	D3	D2	D1	D0
W	1	TRI	DFM	0	BGR	0	0	HWM	0	ORG	0	I/D1	I/D0	AM	0	0	0

AM Control the GRAM update direction.

When AM = "0", the address is updated in horizontal writing direction.

When AM = "1", the address is updated in vertical writing direction.

When a window area is set by registers R50h ~R53h, only the addressed GRAM area is updated based on I/D[1:0] and AM bits setting.

I/D[1:0] Control the address counter (AC) to automatically increase or decrease by 1 when update one pixel display data. Refer to the following figure for the details.

	I/D[1:0] = 00 Horizontal : decrement Vertical : decrement	I/D[1:0] = 01 Horizontal : increment Vertical : decrement	I/D[1:0] = 10 Horizontal : decrement Vertical : increment	I/D[1:0] = 11 Horizontal : increment Vertical : increment
AM = 0 Horizontal				
AM = 1 Vertical				

Figure25 GRAM Access Direction Setting

ORG Moves the origin address according to the ID setting when a window address area is made. This function is enabled when writing data with the window address area using high-speed RAM write.

ORG = "0": The origin address is not moved. In this case, specify the address to start write operation according to the GRAM address map within the window address area.

ORG = "1": The original address "00000h" moves according to the I/D[1:0] setting.

Notes: 1. When ORG=1, only the origin address address"00000h" can be set in the RAM address set registers R20h, and R21h.

2. In RAM read operation, make sure to set ORG=0.

BGR Swap the R and B order of written data.

BGR="0": Follow the RGB order to write the pixel data.

BGR="1": Swap the RGB data to BGR in writing into GRAM.

HWM Set HWM= "1" for high speed GRAM access. In the high-speed access mode, the data are written into GRAM until the 4 words display had been received. If the received data are less than 4 words, the last data will be ignored and not written into GRAM.

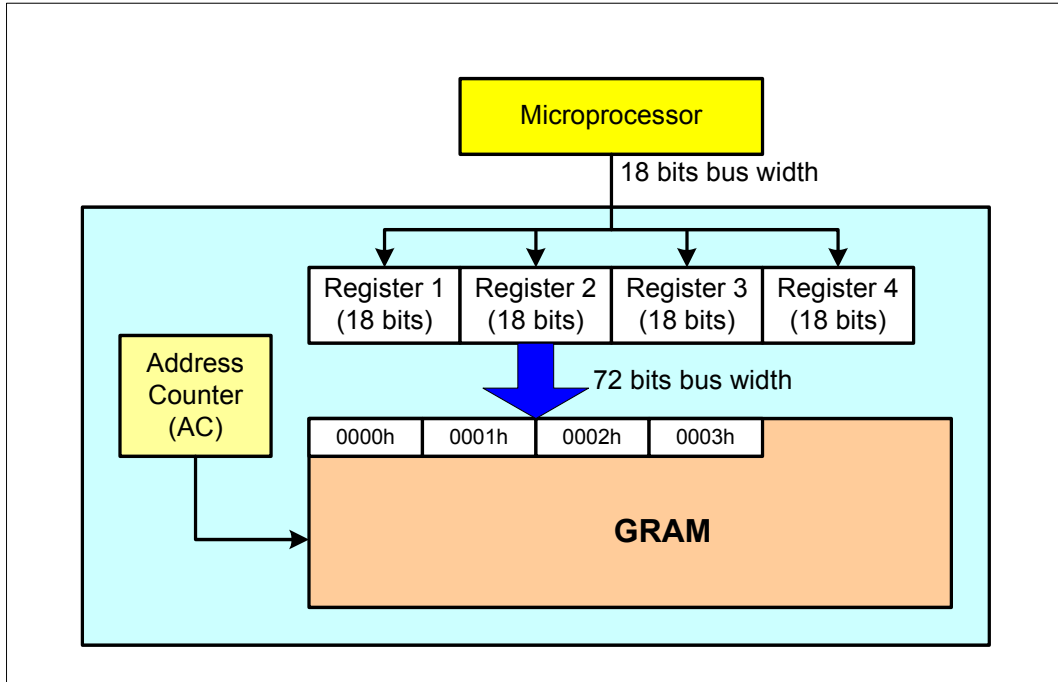

Figure26 GRAM High-speed Write Mode

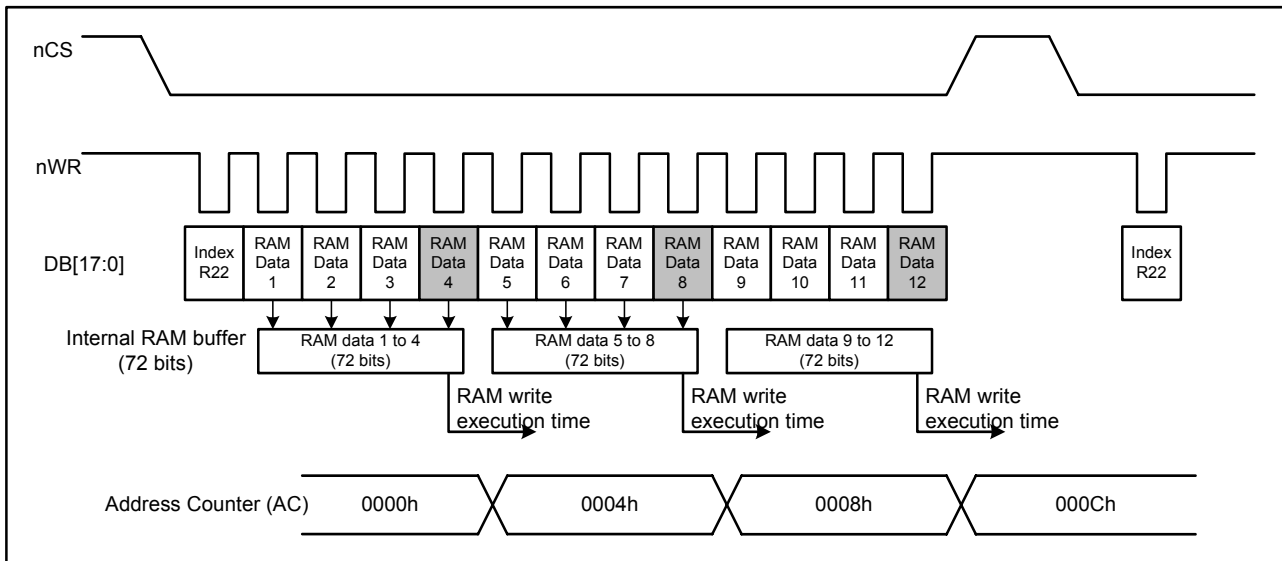

Figure27 High-speed consecutive write operation (in 18/16-bit interface mode)

TRI When TRI = "1", data are transferred to the internal RAM in 8-bit x 3 transfers mode via the 8-bit interface. It is also possible to send data via the 16-bit interface or SPI in the transfer mode that realizes display in 262k colors in combination with DFM bits. When not using these interface modes, be sure to set TRI = "0".

DFM Set the mode of transferring data to the internal RAM when TRI = "1". See the following figures for details.

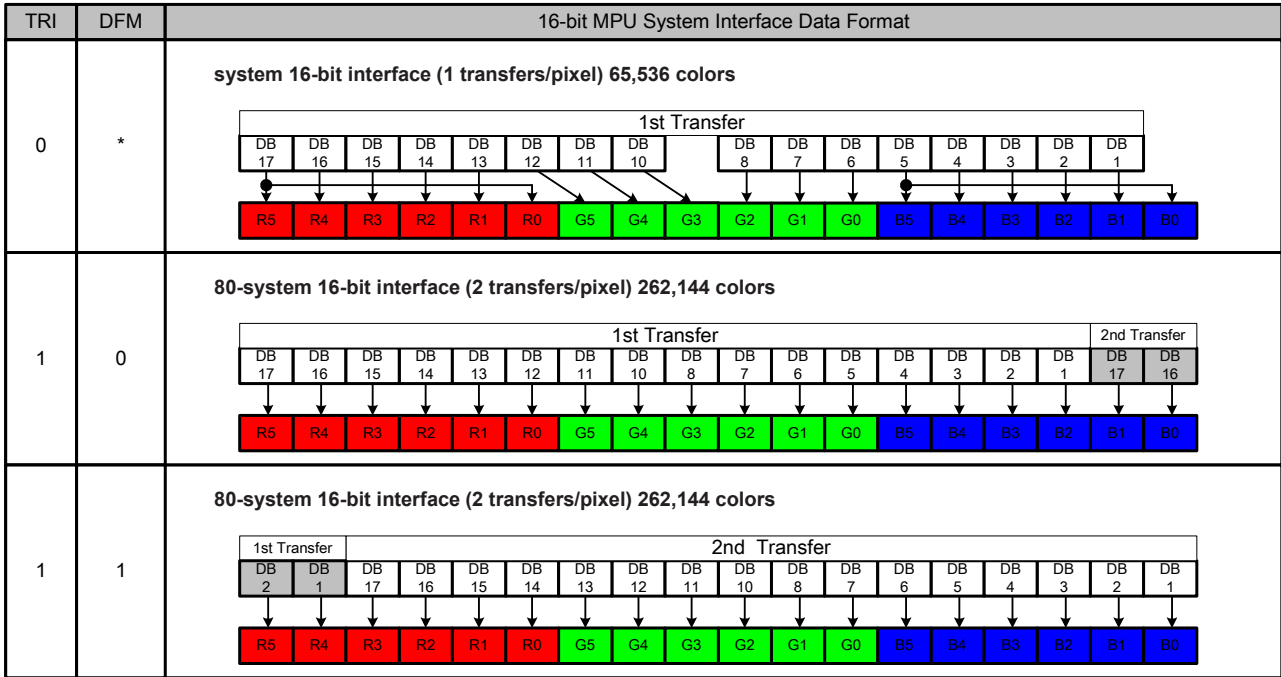

Figure28 16-bit MPU System Interface Data Format

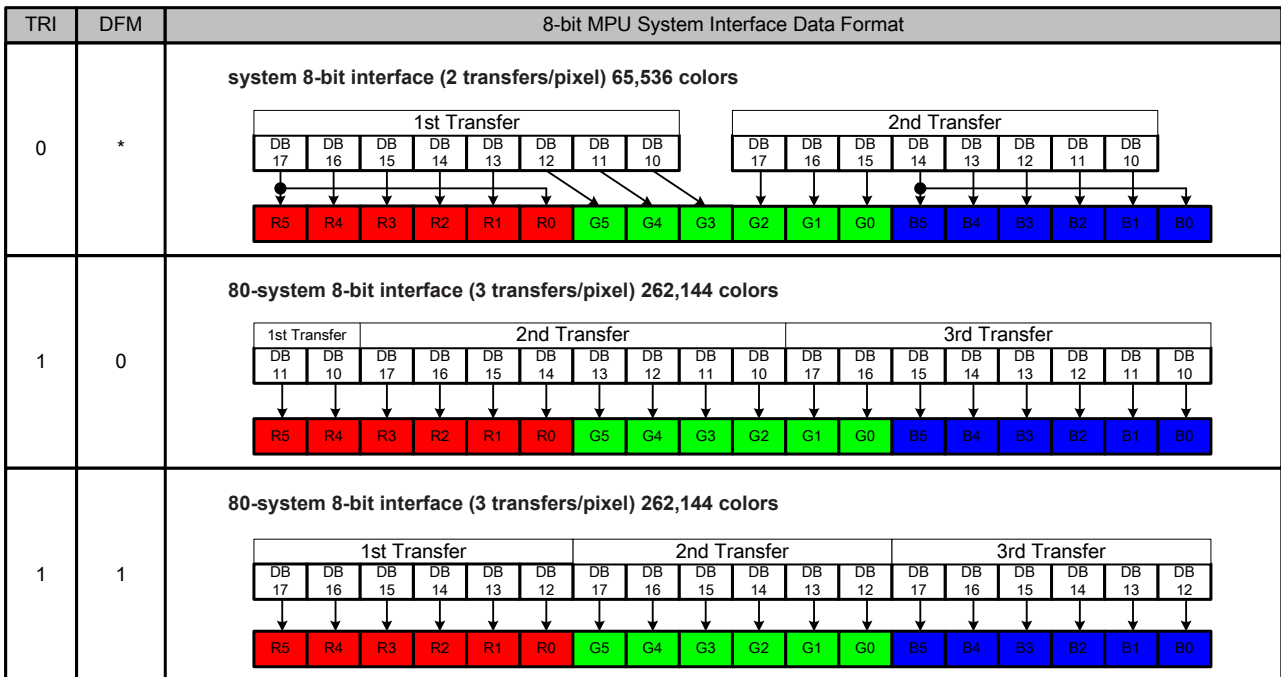

Figure29 8-bit MPU System Interface Data Format

8.2.6. Resizing Control Register (R04h)

R/W	RS	D15	D14	D13	D12	D11	D10	D9	D8	D7	D6	D5	D4	D3	D2	D1	D0
W	1	0	0	0	0	0	0	RCV1	RCV0	0	0	RCH1	RCH0	0	0	RSZ1	RSZ0

RSZ[1:0] Sets the resizing factor.

When the RSZ bits are set for resizing, the ILI9325 writes the data according to the resizing factor so that the original image is displayed in horizontal and vertical dimensions, which are contracted

The information contained herein is the exclusive property of ILI Technology Corp. and shall not be distributed, reproduced, or disclosed in whole or in part without prior written permission of ILI Technology Corp.

according to the factor respectively. See “Resizing function”.

RCH[1:0] Sets the number of remainder pixels in horizontal direction when resizing a picture.

By specifying the number of remainder pixels by RCH bits, the data can be transferred without taking the reminder pixels into consideration. Make sure that RCH = 2’h0 when not using the resizing function (RSZ = 2’h0) or there are no remainder pixels.

RCV[1:0] Sets the number of remainder pixels in vertical direction when resizing a picture.

By specifying the number of remainder pixels by RCV bits, the data can be transferred without taking the reminder pixels into consideration. Make sure that RCV = 2’h0 when not using the resizing function (RSZ = 2’h0) or there are no remainder pixels.

RSZ[1:0]	Resizing factor
00	No resizing (x1)
01	x 1/2
10	Setting prohibited
11	x 1/4

RCH[1:0]	Number of remainder Pixels in Horizontal Direction
00	0 pixel*
01	1 pixel
10	2 pixel
11	3 pixel

RCV[1:0]	Number of remainder Pixels in Vertical Direction
00	0 pixel*
01	1 pixel
10	2 pixel
11	3 pixel

*1 pixel = 1RGB

8.2.7. Display Control 1 (R07h)

R/W	RS	D15	D14	D13	D12	D11	D10	D9	D8	D7	D6	D5	D4	D3	D2	D1	D0
W	1	0	0	PTDE1	PTDE0	0	0	0	BASEE	0	0	GON	DTE	CL	0	D1	D0

D[1:0] Set D[1:0]=”11” to turn on the display panel, and D[1:0]=”00” to turn off the display panel.

A graphics display is turned on the panel when writing D1 = “1”, and is turned off when writing D1 = “0”.

When writing D1 = “0”, the graphics display data is retained in the internal GRAM and the ILI9325 displays the data when writing D1 = “1”. When D1 = “0”, i.e. while no display is shown on the panel, all source outputs becomes the GND level to reduce charging/discharging current, which is generated within the LCD while driving liquid crystal with AC voltage.

When the display is turned off by setting D[1:0] = “01”, the ILI9325 continues internal display operation. When the display is turned off by setting D[1:0] = “00”, the ILI9325 internal display operation is halted completely. In combination with the GON, DTE setting, the D[1:0] setting controls display ON/OFF.

D1	D0	BASEE	Source, VCOM Output	ILI9325 internal operation
0	0	0	GND	Halt
0	1	1	GND	Operate
1	0	0	Non-lit display	Operate
1	1	0	Non-lit display	Operate
1	1	1	Base image display	Operate

Note: 1. data write operation from the microcontroller is performed irrespective of the setting of D[1:0] bits.

2. The D[1:0] setting is valid on both 1st and 2nd displays.

3. The non-lit display level from the source output pins is determined by instruction (PTS).

CL When CL = "1", the 8-color display mode is selected.

CL	Colors
0	262,144
1	8

GON and DTE Set the output level of gate driver G1 ~ G320 as follows

GON	DTE	G1 ~G320 Gate Output
0	0	VGH
0	1	VGH
1	0	VGL
1	1	Normal Display

BASEE

Base image display enable bit. When BASEE = "0", no base image is displayed. The ILI9325 drives liquid crystal at non-lit display level or displays only partial images. When BASEE = "1", the base image is displayed. The D[1:0] setting has higher priority over the BASEE setting.

PTDE[1:0]

Partial image 2 and Partial image 1 enable bits

PTDE1/0 = 0: turns off partial image. Only base image is displayed.

PTDE1/0 = 1: turns on partial image. Set the base image display enable bit to 0 (BASEE = 0).

8.2.8. Display Control 2 (R08h)

R/W	RS	D15	D14	D13	D12	D11	D10	D9	D8	D7	D6	D5	D4	D3	D2	D1	D0
W	1	0	0	0	0	FP3	FP2	FP1	FP0	0	0	0	0	BP3	BP2	BP1	BP0

FP[3:0]/BP[3:0]

The FP[3:0] and BP[3:0] bits specify the line number of front and back porch periods respectively.

When setting the FP[3:0] and BP[3:0] value, the following conditions shall be met:

$$BP + FP \leq 16 \text{ lines}$$

$$FP \geq 2 \text{ lines}$$

$$BP \geq 2 \text{ lines}$$

Set the BP[3:0] and FP[3:0] bits as below for each operation modes

Operation Mode	BP	FP	BP+FP
180 System Interface Operation Mode	BP ≥ 2 lines	FP ≥ 2 lines	FP +BP ≤ 16 lines
RGB interface Operation	BP ≥ 2 lines	FP ≥ 2 lines	FP +BP ≤ 16 lines
VSYNC interface Operation	BP ≥ 2 lines	FP ≥ 2 lines	FP +BP = 16 lines

FP[3:0]	Number of lines for Front Porch
BP[3:0]	Number of lines for Back Porch
0000	Setting Prohibited
0001	Setting Prohibited
0010	2 lines
0011	3 lines
0100	4 lines
0101	5 lines
0110	6 lines
0111	7 lines
1000	8 lines
1001	9 lines
1010	10 lines
1011	11 lines
1100	12 lines
1101	13 lines
1110	14 lines
1111	Setting Prohibited

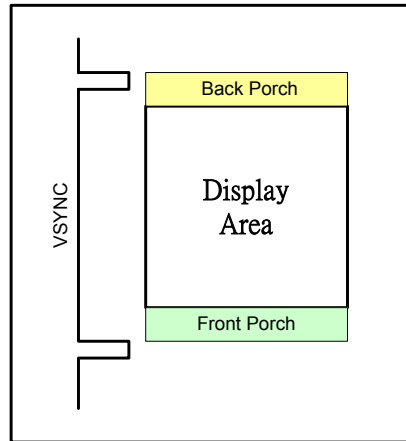

Note: The output timing to the LCD is delayed by 2 lines period from the input of synchronizing signal.

8.2.9. Display Control 3 (R09h)

R/W	RS	D15	D14	D13	D12	D11	D10	D9	D8	D7	D6	D5	D4	D3	D2	D1	D0
W	1	0	0	0	0	0	PTS2	PTS1	PTS0	0	0	PTG1	PTG0	ISC3	ISC2	ISC1	ISC0

ISC[3:0]: Specify the scan cycle interval of gate driver in non-display area when PTG[1:0]="10" to select interval scan. Then scan cycle is set as odd number from 0~29 frame periods. The polarity is inverted every scan cycle.

ISC3	ISC2	ISC1	ISC0	Scan Cycle	f _{FLM} =60 Hz
0	0	0	0	0 frame	-
0	0	0	1	1 frame	17ms
0	0	1	0	3 frame	50ms
0	0	1	1	5 frame	84ms
0	1	0	0	7 frame	117ms
0	1	0	1	9 frame	150ms
0	1	1	0	11 frame	184ms
0	1	1	1	13 frame	217ms
1	0	0	0	15 frame	251ms
1	0	0	1	17 frame	284ms
1	0	1	0	19 frame	317ms
1	0	1	1	21 frame	351ms
1	1	0	0	23 frame	384ms
1	1	0	1	25 frame	418ms
1	1	1	0	27 frame	451ms
1	1	1	1	29 frame	484ms

PTG[1:0] Set the scan mode in non-display area.

PTG1	PTG0	Gate outputs in non-display area	Source outputs in non-display area	Vcom output
0	0	Normal scan	Set with the PTS[2:0] bits	VcomH/VcomL
0	1	Setting Prohibited	-	-
1	0	Interval scan	Set with the PTS[2:0] bits	VcomH/VcomL
1	1	Setting Prohibited	-	-

PTS[2:0]

Set the source output level in non-display area drive period (front/back porch period and blank area between partial displays).

When PTS[2] = 1, the operation of amplifiers which generates the grayscales other than V0 and V63 are halted and the step-up clock frequency becomes half the normal frequency in non-display drive period in order to reduce power consumption.

PTS[2:0]	Source output level		Grayscale amplifier in operation	Step-up clock frequency
	Positive polarity	Negative polarity		
000	V63	V0	V63 to V0	Register Setting (DC1, DC0)
001	Setting Prohibited	Setting Prohibited	-	-
010	GND	GND	V63 to V0	Register Setting (DC1, DC0)
011	Hi-Z	Hi-Z	V63 to V0	Register Setting (DC1, DC0)
100	V63	V0	V63 and V0	frequency setting by DC1, DC0
101	Setting Prohibited	Setting Prohibited	-	-
110	GND	GND	V63 and V0	frequency setting by DC1, DC0
111	Hi-Z	Hi-Z	V63 and V0	frequency setting by DC1, DC0

Notes: 1. The power efficiency can be improved by halting grayscale amplifiers and slowing down the step-up clock frequency only in non-display drive period.

2. The gate output level in non-lit display area drive period is determined by PTG[1:0].

8.2.10. Display Control 4 (R0Ah)

R/W	RS	D15	D14	D13	D12	D11	D10	D9	D8	D7	D6	D5	D4	D3	D2	D1	D0
W	1	0	0	0	0	0	0	0	0	0	0	0	0	FMARKOE	FMI2	FMI1	FMI0

FMI[2:0] Set the output interval of FMARK signal according to the display data rewrite cycle and data transfer rate.

FMARKOE When FMARKOE=1, ILI9325 starts to output FMARK signal in the output interval set by FMI[2:0] bits.

FMI[2:0]	Output Interval
000	1 frame
001	2 frame
011	4 frame
101	6 frame
Others	Setting disabled

8.2.11. RGB Display Interface Control 1 (R0Ch)

R/W	RS	D15	D14	D13	D12	D11	D10	D9	D8	D7	D6	D5	D4	D3	D2	D1	D0
W	1	0	ENC2	ENC1	ENC0	0	0	0	RM	0	0	DM1	DM0	0	0	RIM1	RIM0

RIM[1:0] Select the RGB interface data width.

RIM1	RIM0	RGB Interface Mode
0	0	18-bit RGB interface (1 transfer/pixel), DB[17:0]
0	1	16-bit RGB interface (1 transfer/pixel), DB[17:13] and DB[11:1]
1	0	6-bit RGB interface (3 transfers/pixel), DB[17:12]
1	1	Setting disabled

Note1: Registers are set only by the system interface.

Note2: Be sure that one pixel (3 dots) data transfer finished when interface switch.

DM[1:0] Select the display operation mode.

DM1	DM0	Display Interface
0	0	Internal system clock
0	1	RGB interface
1	0	VSYNC interface
1	1	Setting disabled

The DM[1:0] setting allows switching between internal clock operation mode and external display interface operation mode. However, switching between the RGB interface operation mode and the VSYNC interface operation mode is prohibited.

RM Select the interface to access the GRAM.

Set RM to “1” when writing display data by the RGB interface.

RM	Interface for RAM Access
0	System interface/VSYNC interface
1	RGB interface

Display State	Operation Mode	RAM Access (RM)	Display Operation Mode (DM[1:0])
Still pictures	Internal clock operation	System interface (RM = 0)	Internal clock operation (DM[1:0] = 00)
Moving pictures	RGB interface (1)	RGB interface (RM = 1)	RGB interface (DM[1:0] = 01)
Rewrite still picture area while RGB interface Displaying moving pictures.		System interface (RM = 0)	RGB interface (DM[1:0] = 01)
Moving pictures	VSYNC interface	System interface (RM = 0)	VSYNC interface (DM[1:0] = 10)

Note 1: Registers are set only via the system interface or SPI interface.

Note 2: Refer to the flowcharts of “RGB Input Interface” section for the mode switch.

ENC[2:0] Set the GRAM write cycle through the RGB interface

ENC[2:0]	GRAM Write Cycle (Frame periods)
000	1 Frame
001	2 Frames
010	3 Frames
011	4 Frames

100	5 Frames
101	6 Frames
110	7 Frames
111	8 Frames

8.2.12. Frame Marker Position (R0Dh)

R/W	RS	D15	D14	D13	D12	D11	D10	D9	D8	D7	D6	D5	D4	D3	D2	D1	D0
W	1	0	0	0	0	0	0	0	FMP8	FMP7	FMP6	FMP5	FMP4	FMP3	FMP2	FMP1	FMP0

EMP[8:0] Sets the output position of frame cycle (frame marker).

When FMP[8:0]=0, a high-active pulse FMARK is output at the start of back porch period for one display line period (1H).

Make sure the $9'h000 \leq FMP \leq BP+NL+FP$

FMP[8:0]	FMARK Output Position
9'h000	0 th line
9'h001	1 st line
9'h002	2 nd line
9'h003	3 rd line
⋮	⋮
9'h175	373 rd line
9'h176	374 th line
9'h177	375 th line

8.2.13. RGB Display Interface Control 2 (R0Fh)

R/W	RS	D15	D14	D13	D12	D11	D10	D9	D8	D7	D6	D5	D4	D3	D2	D1	D0
W	1	0	0	0	0	0	0	0	0	0	0	0	VSPL	HSPL	0	EPL	DPL

DPL: Sets the signal polarity of the DOTCLK pin.

DPL = "0" The data is input on the rising edge of DOTCLK

DPL = "1" The data is input on the falling edge of DOTCLK

EPL: Sets the signal polarity of the ENABLE pin.

EPL = "0" The data DB17-0 is written when ENABLE = "0". Disable data write operation when ENABLE = "1".

EPL = "1" The data DB17-0 is written when ENABLE = "1". Disable data write operation when ENABLE = "0".

HSPL: Sets the signal polarity of the HSYNC pin.

HSPL = "0" Low active

HSPL = "1" High active

VSPL: Sets the signal polarity of the VSYNC pin.

VSPL = "0" Low active

VSPL = "1" High active

8.2.14. Power Control 1 (R10h)

R/W	RS	D15	D14	D13	D12	D11	D10	D9	D8	D7	D6	D5	D4	D3	D2	D1	D0
W	1	0	0	0	SAP	0	BT2	BT1	BT0	APE	AP2	AP1	AP0	0	DSTB	SLP	STB

SLP: When SLP = 1, ILI9325 enters the sleep mode and the display operation stops except the RC oscillator to reduce the power consumption. In the sleep mode, the GRAM data and instructions cannot be updated except the following two instructions.

- a. Exit sleep mode (SLP = "0")
- b. Start oscillation

STB: When STB = 1, ILI9325 enters the standby mode and the display operation stops except the GRAM power supply to reduce the power consumption. In the sleep mode, the GRAM data and instructions cannot be updated except the following two instructions.

- a. Exit standby mode (STB = "0")
- b. Start oscillation

DSTB: When DSTB = 1, the ILI9325 enters the deep standby mode. In deep standby mode, the internal logic power supply is turned off to reduce power consumption. The GRAM data and instruction setting are not maintained when the ILI9325 enters the deep standby mode, and they must be reset after exiting deep standby mode.

AP[2:0]: Adjusts the constant current in the operational amplifier circuit in the LCD power supply circuit. The larger constant current enhances the drivability of the LCD, but it also increases the current consumption. Adjust the constant current taking the trade-off into account between the display quality and the current consumption. In no-display period, set AP[2:0] = "000" to halt the operational amplifier circuits and the step-up circuits to reduce current consumption.

AP[2:0]	Gamma driver amplifiers	Source driver amplifiers
000	Halt	Halt
001	1.00	1.00
010	1.00	0.75
011	1.00	0.50
100	0.75	1.00
101	0.75	0.75
110	0.75	0.50
111	0.50	0.50

SAP: Source Driver output control

SAP=0, Source driver is disabled.

SAP=1, Source driver is enabled.

When starting the charge-pump of LCD in the Power ON stage, make sure that SAP=0, and set the SAP=1, after starting up the LCD power supply circuit.

APE: Power supply enable bit.

Set APE = "1" to start the generation of power supply according to the power supply startup sequence.

BT[3:0]: Sets the factor used in the step-up circuits.

Select the optimal step-up factor for the operating voltage. To reduce power consumption, set a smaller factor.

BT[2:0]	DDVDH	VCL	VGH	VGL
3'h0	Vci1 x 2	- Vci1	Vci1 x 6	- Vci1 x 5
3'h1	Vci1 x 2	- Vci1		- Vci1 x 4
3'h2				- Vci1 x 3
3'h3	Vci1 x 2	- Vci1	Vci1 x 5	- Vci1 x 5
3'h4				- Vci1 x 4
3'h5				- Vci1 x 3
3'h6	Vci1 x 2	- Vci1	Vci1 x 4	- Vci1 x 4
3'h7				- Vci1 x 3

Notes: 1. Connect capacitors to the capacitor connection pins when generating DDVDH, VGH, VGL and VCL levels.

2. Make sure DDVDH = 6.0V (max.), VGH = 15.0V (max.), VGL = - 12.5V (max) and VCL= -3.0V (max.)

8.2.15. Power Control 2 (R11h)

R/W	RS	D15	D14	D13	D12	D11	D10	D9	D8	D7	D6	D5	D4	D3	D2	D1	D0
W	1	0	0	0	0	0	DC12	DC11	DC10	0	DC02	DC01	DC00	0	VC2	VC1	VC0

VC[2:0] Sets the ratio factor of Vci to generate the reference voltages Vci1.

VC2	VC1	VC0	Vci1 voltage
0	0	0	0.95 x Vci
0	0	1	0.90 x Vci
0	1	0	0.85 x Vci
0	1	1	0.80 x Vci
1	0	0	0.75 x Vci
1	0	1	0.70 x Vci
1	1	0	Disabled
1	1	1	1.0 x Vci

DC0[2:0]: Selects the operating frequency of the step-up circuit 1. The higher step-up operating frequency enhances the drivability of the step-up circuit and the quality of display but increases the current consumption. Adjust the frequency taking the trade-off between the display quality and the current consumption into account.

DC1[2:0]: Selects the operating frequency of the step-up circuit 2. The higher step-up operating frequency enhances the drivability of the step-up circuit and the quality of display but increases the current consumption. Adjust the frequency taking the trade-off between the display quality and the current consumption into account.

DC02	DC01	DC00	Step-up circuit1 step-up frequency (f _{DCDC1})	DC12	DC11	DC10	Step-up circuit2 step-up frequency (f _{DCDC2})
0	0	0	Fosc	0	0	0	Fosc / 4

The information contained herein is the exclusive property of ILI Technology Corp. and shall not be distributed, reproduced, or disclosed in whole or in part without prior written permission of ILI Technology Corp.

0	0	1	Fosc / 2	0	0	1	Fosc / 8
0	1	0	Fosc / 4	0	1	0	Fosc / 16
0	1	1	Fosc / 8	0	1	1	Fosc / 32
1	0	0	Fosc / 16	1	0	0	Fosc / 64
1	0	1	Fosc / 32	1	0	1	Fosc / 128
1	1	0	Fosc / 64	1	1	0	Fosc / 256
1	1	1	Halt step-up circuit 1	1	1	1	Halt step-up circuit 2

Note: Be sure $f_{DCDC1} \geq f_{DCDC2}$ when setting DC0[2:0] and DC1[2:0].

8.2.16. Power Control 3 (R12h)

R/W	RS	D15	D14	D13	D12	D11	D10	D9	D8	D7	D6	D5	D4	D3	D2	D1	D0
W	1	0	0	0	0	0	0	0	0	VCIRE	0	0	PON	VRH3	VRH2	VRH1	VRH0

VRH[3:0] Set the amplifying rate (1.6 ~ 1.9) of Vci applied to output the VREG1OUT level, which is a reference level for the VCOM level and the grayscale voltage level.

VCIRE: Select the external reference voltage Vci or internal reference voltage VCIR.

VCIRE=0	External reference voltage Vci (default)
VCIRE=1	Internal reference voltage 2.5V

VCIRE =0					VCIRE =1				
VRH3	VRH2	VRH1	VRH0	VREG1OUT	VRH3	VRH2	VRH1	VRH0	VREG1OUT
0	0	0	0	Halt	0	0	0	0	Halt
0	0	0	1	Vci x 2.00	0	0	0	1	2.5V x 2.00 = 5.000V
0	0	1	0	Vci x 2.05	0	0	1	0	2.5V x 2.05 = 5.125V
0	0	1	1	Vci x 2.10	0	0	1	1	2.5V x 2.10 = 5.250V
0	1	0	0	Vci x 2.20	0	1	0	0	2.5V x 2.20 = 5.500V
0	1	0	1	Vci x 2.30	0	1	0	1	2.5V x 2.30 = 5.750V
0	1	1	0	Vci x 2.40	0	1	1	0	2.5V x 2.40 = 6.000V
0	1	1	1	Vci x 2.40	0	1	1	1	2.5V x 2.40 = 6.000V
1	0	0	0	Vci x 1.60	1	0	0	0	2.5V x 1.60 = 4.000V
1	0	0	1	Vci x 1.65	1	0	0	1	2.5V x 1.65 = 4.125V
1	0	1	0	Vci x 1.70	1	0	1	0	2.5V x 1.70 = 4.250V
1	0	1	1	Vci x 1.75	1	0	1	1	2.5V x 1.75 = 4.375V
1	1	0	0	Vci x 1.80	1	1	0	0	2.5V x 1.80 = 4.500V
1	1	0	1	Vci x 1.85	1	1	0	1	2.5V x 1.85 = 4.625V
1	1	1	0	Vci x 1.90	1	1	1	0	2.5V x 1.90 = 4.750V
1	1	1	1	Vci x 1.95	1	1	1	1	2.5V x 1.95 = 4.875V

When $VCI < 2.5V$, Internal reference voltage will be same as VCI.

Make sure that VC and VRH setting restriction: $VREG1OUT \leq (DDVDH - 0.5)V$.

PON: Control ON/OFF of circuit3 (VGL) output.

PON=0	VGL output is disable
PON=1	VGL output is enable

8.2.17. Power Control 4 (R13h)

R/W	RS	D15	D14	D13	D12	D11	D10	D9	D8	D7	D6	D5	D4	D3	D2	D1	D0
W	1	0	0	0	VDV4	VDV3	VDV2	VDV1	VDV0	0	0	0	0	0	0	0	0

The information contained herein is the exclusive property of ILI Technology Corp. and shall not be distributed, reproduced, or disclosed in whole or in part without prior written permission of ILI Technology Corp.

VDV[4:0] Select the factor of VREG1OUT to set the amplitude of Vcom alternating voltage from 0.70 to 1.24 x VREG1OUT .

VDV4	VDV3	VDV2	VDV1	VDV0	VCOM amplitude	VDV4	VDV3	VDV2	VDV1	VDV0	VCOM amplitude
0	0	0	0	0	VREG1OUT x 0.70	1	0	0	0	0	VREG1OUT x 0.94
0	0	0	0	1	VREG1OUT x 0.72	1	0	0	0	1	VREG1OUT x 0.96
0	0	0	1	0	VREG1OUT x 0.74	1	0	0	1	0	VREG1OUT x 0.98
0	0	0	1	1	VREG1OUT x 0.76	1	0	0	1	1	VREG1OUT x 1.00
0	0	1	0	0	VREG1OUT x 0.78	1	0	1	0	0	VREG1OUT x 1.02
0	0	1	0	1	VREG1OUT x 0.80	1	0	1	0	1	VREG1OUT x 1.04
0	0	1	1	0	VREG1OUT x 0.82	1	0	1	1	0	VREG1OUT x 1.06
0	0	1	1	1	VREG1OUT x 0.84	1	0	1	1	1	VREG1OUT x 1.08
0	1	0	0	0	VREG1OUT x 0.86	1	1	0	0	0	VREG1OUT x 1.10
0	1	0	0	1	VREG1OUT x 0.88	1	1	0	0	1	VREG1OUT x 1.12
0	1	0	1	0	VREG1OUT x 0.90	1	1	0	1	0	VREG1OUT x 1.14
0	1	0	1	1	VREG1OUT x 0.92	1	1	0	1	1	VREG1OUT x 1.16
0	1	1	0	0	VREG1OUT x 0.94	1	1	1	0	0	VREG1OUT x 1.18
0	1	1	0	1	VREG1OUT x 0.96	1	1	1	0	1	VREG1OUT x 1.20
0	1	1	1	0	VREG1OUT x 0.98	1	1	1	1	0	VREG1OUT x 1.22
0	1	1	1	1	VREG1OUT x 1.00	1	1	1	1	1	VREG1OUT x 1.24

Set VDV[4:0] to let Vcom amplitude less than 6V.

8.2.18. GRAM Horizontal/Vertical Address Set (R20h, R21h)

R/W	RS	D15	D14	D13	D12	D11	D10	D9	D8	D7	D6	D5	D4	D3	D2	D1	D0
W	1	0	0	0	0	0	0	0	0	AD7	AD6	AD5	AD4	AD3	AD2	AD1	AD0
W	1	0	0	0	0	0	0	0	AD16	AD15	AD14	AD13	AD12	AD11	AD10	AD9	AD8

AD[16:0] Set the initial value of address counter (AC).

The address counter (AC) is automatically updated in accordance to the setting of the AM, I/D bits as data is written to the internal GRAM. The address counter is not automatically updated when read data from the internal GRAM.

AD[16:0]	GRAM Data Map
17'h00000 ~ 17'h000EF	1 st line GRAM Data
17'h00100 ~ 17'h001EF	2 nd line GRAM Data
17'h00200 ~ 17'h002EF	3 rd line GRAM Data
17'h00300 ~ 17'h003EF	4 th line GRAM Data
17'h13D00 ~ 17' h13DEF	318 th line GRAM Data
17'h13E00 ~ 17' h13EEF	319 th line GRAM Data
17'h13F00 ~ 17'h13FEF	320 th line GRAM Data

Note1: When the RGB interface is selected (RM = "1"), the address AD[16:0] is set to the address counter every frame on the falling edge of VSYNC.

Note2: When the internal clock operation or the VSYNC interface mode is selected (RM = "0"), the address AD[16:0] is set to address counter when update register R21.

8.2.19. Write Data to GRAM (R22h)

R/W	RS	D17	D16	D15	D14	D13	D12	D11	D10	D9	D8	D7	D6	D5	D4	D3	D2	D1	D0
W	1	RAM write data (WD[17:0], the DB[17:0] pin assignment differs for each interface.																	

This register is the GRAM access port. When update the display data through this register, the address

counter (AC) is increased/decreased automatically.

8.2.20. Read Data from GRAM (R22h)

R/W	RS	D17	D16	D15	D14	D13	D12	D11	D10	D9	D8	D7	D6	D5	D4	D3	D2	D1	D0
R	1	RAM Read Data (RD[17:0], the DB[17:0] pin assignment differs for each interface).																	

RD[17:0] Read 18-bit data from GRAM through the read data register (RDR).

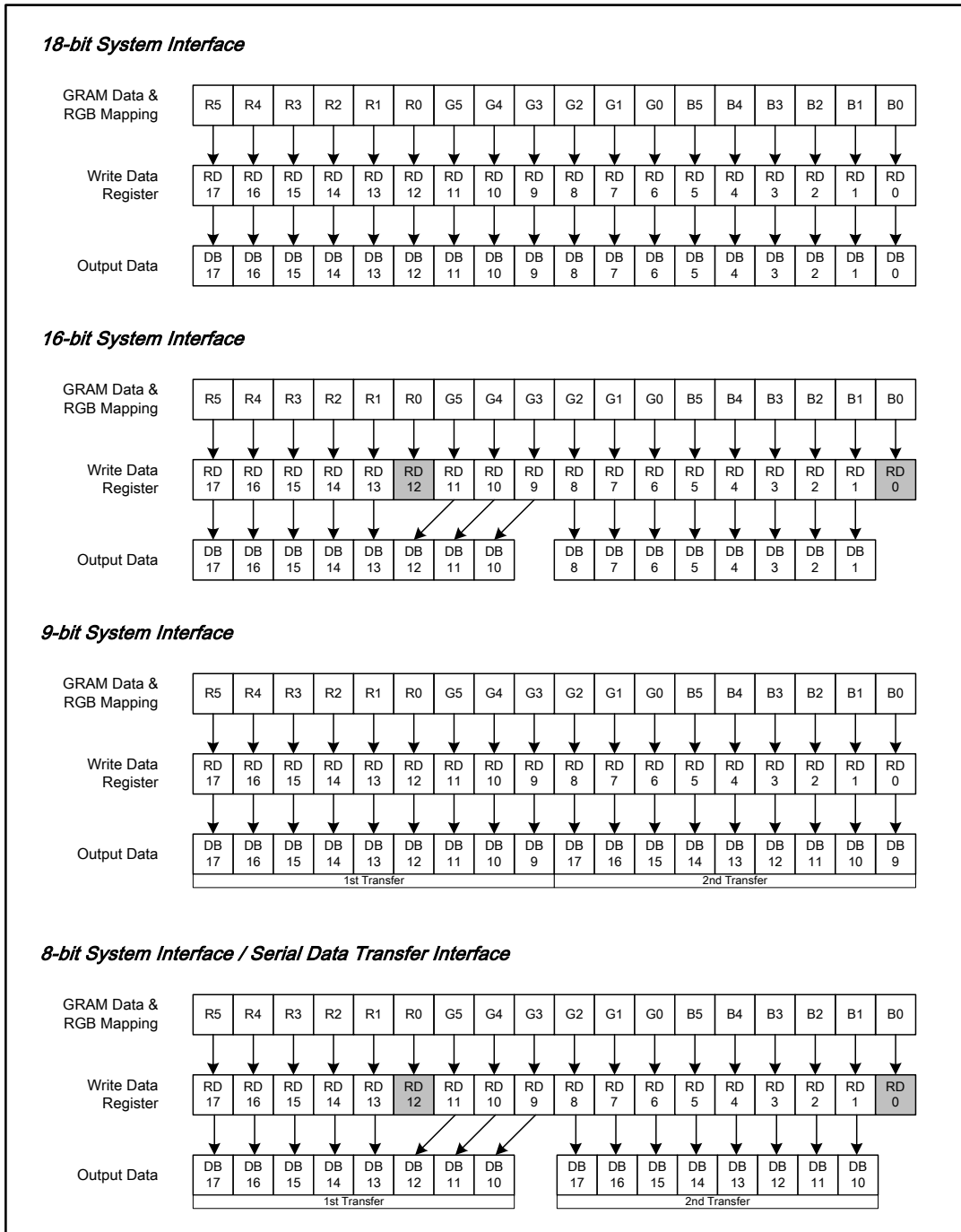

Figure 30 Data Read from GRAM through Read Data Register in 18-/16-/9-/8-bit Interface Mode

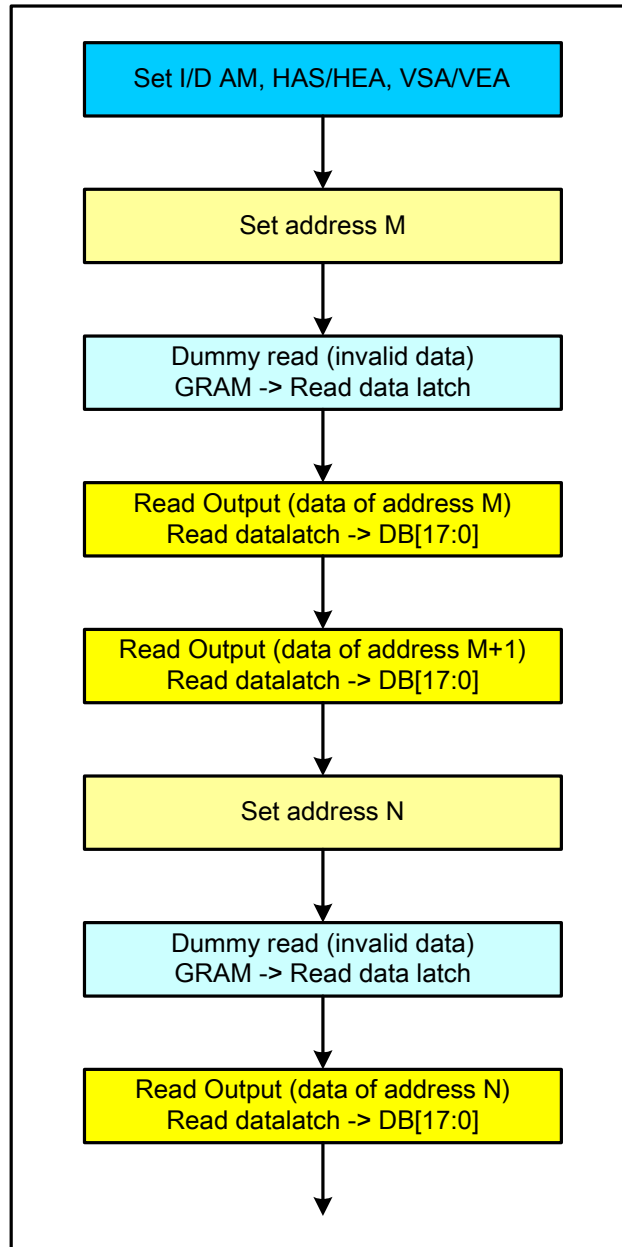

Figure 31 GRAM Data Read Back Flow Chart

8.2.21. Power Control 7 (R29h)

R/W	RS	D15	D14	D13	D12	D11	D10	D9	D8	D7	D6	D5	D4	D3	D2	D1	D0
W	1	0	0	0	0	0	0	0	0	0	0	VCM5	VCM4	VCM3	VCM2	VCM1	VCM0

VCM[5:0] Set the internal VcomH voltage.

VCM5	VCM4	VCM3	VCM2	VCM1	VCM0	VCOMH	VCM5	VCM4	VCM3	VCM2	VCM1	VCM0	VCOMH
0	0	0	0	0	0	VREG1OUT 0.685	x	1	0	0	0	0	VREG1OUT 0.845
0	0	0	0	0	1	VREG1OUT 0.690	x	1	0	0	0	1	VREG1OUT 0.850
0	0	0	0	1	0	VREG1OUT 0.695	x	1	0	0	0	1	VREG1OUT 0.855
0	0	0	0	1	1	VREG1OUT 0.700	x	1	0	0	0	1	VREG1OUT 0.860
0	0	0	1	0	0	VREG1OUT	x	1	0	0	1	0	VREG1OUT

The information contained herein is the exclusive property of ILI Technology Corp. and shall not be distributed, reproduced, or disclosed in whole or in part without prior written permission of ILI Technology Corp.

						0.705													0.865
0	0	0	1	0	1	VREG1OUT	x	1	0	0	1	0	1	VREG1OUT	x				0.870
						0.710													
0	0	0	1	1	0	VREG1OUT	x	1	0	0	1	1	0	VREG1OUT	x				0.875
						0.715													
0	0	0	1	1	1	VREG1OUT	x	1	0	0	1	1	1	VREG1OUT	x				0.880
						0.720													
0	0	1	0	0	0	VREG1OUT	x	1	0	1	0	0	0	VREG1OUT	x				0.885
						0.725													
0	0	1	0	0	1	VREG1OUT	x	1	0	1	0	0	1	VREG1OUT	x				0.890
						0.730													
0	0	1	0	1	0	VREG1OUT	x	1	0	1	0	1	0	VREG1OUT	x				0.895
						0.735													
0	0	1	0	1	1	VREG1OUT	x	1	0	1	0	1	1	VREG1OUT	x				0.900
						0.740													
0	0	1	1	0	0	VREG1OUT	x	1	0	1	1	0	0	VREG1OUT	x				0.905
						0.745													
0	0	1	1	0	1	VREG1OUT	x	1	0	1	1	0	1	VREG1OUT	x				0.910
						0.750													
0	0	1	1	1	0	VREG1OUT	x	1	0	1	1	1	0	VREG1OUT	x				0.915
						0.755													
0	0	1	1	1	1	VREG1OUT	x	1	0	1	1	1	1	VREG1OUT	x				0.920
						0.760													
0	1	0	0	0	0	VREG1OUT	x	1	1	0	0	0	0	VREG1OUT	x				0.925
						0.765													
0	1	0	0	0	1	VREG1OUT	x	1	1	0	0	0	1	VREG1OUT	x				0.930
						0.770													
0	1	0	0	1	0	VREG1OUT	x	1	1	0	0	1	0	VREG1OUT	x				0.935
						0.775													
0	1	0	0	1	1	VREG1OUT	x	1	1	0	0	1	1	VREG1OUT	x				0.940
						0.780													
0	1	0	1	0	0	VREG1OUT	x	1	1	0	1	0	0	VREG1OUT	x				0.945
						0.785													
0	1	0	1	0	1	VREG1OUT	x	1	1	0	1	0	1	VREG1OUT	x				0.950
						0.790													
0	1	0	1	1	0	VREG1OUT	x	1	1	0	1	1	0	VREG1OUT	x				0.955
						0.795													
0	1	0	1	1	1	VREG1OUT	x	1	1	0	1	1	1	VREG1OUT	x				0.960
						0.800													
0	1	1	0	0	0	VREG1OUT	x	1	1	1	0	0	0	VREG1OUT	x				0.965
						0.805													
0	1	1	0	0	1	VREG1OUT	x	1	1	1	0	0	1	VREG1OUT	x				0.970
						0.810													
0	1	1	0	1	0	VREG1OUT	x	1	1	1	0	1	0	VREG1OUT	x				0.975
						0.815													
0	1	1	0	1	1	VREG1OUT	x	1	1	1	0	1	1	VREG1OUT	x				0.980
						0.820													
0	1	1	1	0	0	VREG1OUT	x	1	1	1	1	0	0	VREG1OUT	x				0.985
						0.825													
0	1	1	1	0	1	VREG1OUT	x	1	1	1	1	0	1	VREG1OUT	x				0.990
						0.830													
0	1	1	1	1	0	VREG1OUT	x	1	1	1	1	1	0	VREG1OUT	x				0.995
						0.835													
0	1	1	1	1	1	VREG1OUT	x	1	1	1	1	1	1	VREG1OUT	x				1.000
						0.840													

8.2.22. Frame Rate and Color Control (R2Bh)

R/W	RS	D15	D14	D13	D12	D11	D10	D9	D8	D7	D6	D5	D4	D3	D2	D1	D0
W	1	0	0	0	0	0	0	0	0	0	0	0	0	FRS3	FRS2	FRS1	FRS0

FRS[4:0] Set the frame rate when the internal resistor is used for oscillator circuit.

FRS[3:0]	FRS[3:0]	Frame Rate
0000	4'h0	31

0001	4'h1	33
0010	4'h2	35
0011	4'h3	37
0100	4'h4	40
0101	4'h5	43
0110	4'h6	46
0111	4'h7	50
1000	4'h8	54
1001	4'h9	60
1010	4'hA	66
1011	4'hB	74
1100	4'hC	85
1101	4'hD	99
1110	4'hE	119
1111	4'hF	Setting Prohibited

8.2.23. Gamma Control (R30h ~ R3Dh)

	R/W	RS	D15	D14	D13	D12	D11	D10	D9	D8	D7	D6	D5	D4	D3	D2	D1	D0
R30h	W	1	0	0	0	0	0	KP1[2]	KP1[1]	KP1[0]	0	0	0	0	0	KP0[2]	KP0[1]	KP0[0]
R31h	W	1	0	0	0	0	0	KP3[2]	KP3[1]	KP3[0]	0	0	0	0	0	KP2[2]	KP2[1]	KP2[0]
R32h	W	1	0	0	0	0	0	KP5[2]	KP5[1]	KP5[0]	0	0	0	0	0	KP4[2]	KP4[1]	KP4[0]
R35h	W	1	0	0	0	0	0	RP1[2]	RP1[1]	RP1[0]	0	0	0	0	0	RP0[2]	RP0[1]	RP0[0]
R36h	W	1	0	0	0	VRP1[4]	VRP1[3]	VRP1[2]	VRP1[1]	VRP1[0]	0	0	0	0	VRP0[3]	VRP0[2]	VRP0[1]	VRP0[0]
R37h	W	1	0	0	0	0	0	KN1[2]	KN1[1]	KN1[0]	0	0	0	0	0	KN0[2]	KN0[1]	KN0[0]
R38h	W	1	0	0	0	0	0	KN3[2]	KN3[1]	KN3[0]	0	0	0	0	0	KN2[2]	KN2[1]	KN2[0]
R39h	W	1	0	0	0	0	0	KN5[2]	KN5[1]	KN5[0]	0	0	0	0	0	KN4[2]	KN4[1]	KN4[0]
R3Ch	W	1	0	0	0	0	0	RN1[2]	RN1[1]	RN1[0]	0	0	0	0	0	RN0[2]	RN0[1]	RN0[0]
R3Dh	W	1	0	0	0	VRN1[4]	VRN1[3]	VRN1[2]	VRN1[1]	VRN1[0]	0	0	0	0	VRN0[3]	VRN0[2]	VRN0[1]	VRN0[0]

KP5-0[2:0] : γ fine adjustment register for positive polarity

RP1-0[2:0] : γ gradient adjustment register for positive polarity

VRP1-0[4:0] : γ amplitude adjustment register for positive polarity

KN5-0[2:0] : γ fine adjustment register for negative polarity

RN1-0[2:0] : γ gradient adjustment register for negative polarity

VRN1-0[4:0] : γ amplitude adjustment register for negative polarity

For details “ γ -Correction Function” section.

8.2.24. Horizontal and Vertical RAM Address Position (R50h, R51h, R52h, R53h)

	R/W	RS	D15	D14	D13	D12	D11	D10	D9	D8	D7	D6	D5	D4	D3	D2	D1	D0
R50h	W	1	0	0	0	0	0	0	0	0	HSA7	HSA6	HSA5	HSA4	HSA3	HSA2	HSA1	HSA0
R51h	W	1	0	0	0	0	0	0	0	0	HEA7	HEA6	HEA5	HEA4	HEA3	HEA2	HEA1	HEA0
R52h	W	1	0	0	0	0	0	0	0	VSA8	VSA7	VSA6	VSA5	VSA4	VSA3	VSA2	VSA1	VSA0
R53h	W	1	0	0	0	0	0	0	0	VEA8	VEA7	VEA6	VEA5	VEA4	VEA3	VEA2	VEA1	VEA0

HSA[7:0]/HEA[7:0] HSA[7:0] and HEA[7:0] represent the respective addresses at the start and end of the window address area in horizontal direction. By setting HSA and HEA bits, it is possible to limit the area on the GRAM horizontally for writing data. The HSA and HEA bits must be set before starting RAM write operation. In setting these bits, be sure “00”h ≤ HSA[7:0] < HEA[7:0] ≤ “EF”h. and “04”h ≤ HEA-HAS.

VSA[8:0]/VEA[8:0] VSA[8:0] and VEA[8:0] represent the respective addresses at the start and end of the window address area in vertical direction. By setting VSA and VEA bits, it is possible to limit the area on the GRAM vertically for writing data. The VSA and VEA bits must be set before starting RAM write operation. In setting, be sure “000”h ≤ VSA[8:0] < VEA[8:0] ≤ “13F”h.

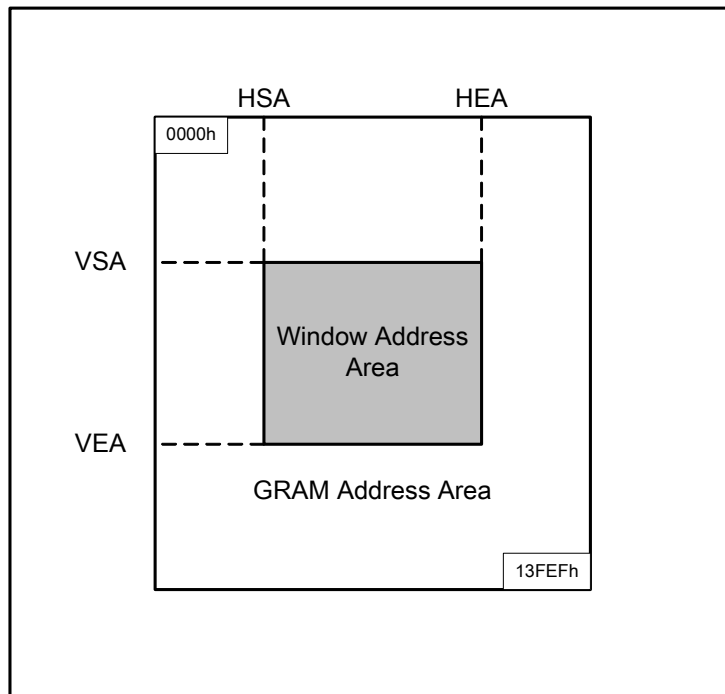

Figure 32 GRAM Access Range Configuration

$$“00”h \leq HAS[7:0] \leq HEA[7:0] \leq “EF”h$$

$$“00”h \leq VSA[7:0] \leq VEA[7:0] \leq “13F”h$$

Note1. The window address range must be within the GRAM address space.

Note2. Data are written to GRAM in four-words when operating in high speed mode, the dummy write operations should be inserted depending on the window address area. For details, see the High-Speed RAM Write Function section.

8.2.25. Gate Scan Control (R60h, R61h, R6Ah)

	R/W	RS	D15	D14	D13	D12	D11	D10	D9	D8	D7	D6	D5	D4	D3	D2	D1	D0
R60h	W	1	GS	0	NL5	NL4	NL3	NL2	NL1	NL0	0	0	SCN5	SCN4	SCN3	SCN2	SCN1	SCN0
R61h	W	1	0	0	0	0	0	0	0	0	0	0	0	0	0	NDL	VLE	REV

The information contained herein is the exclusive property of ILI Technology Corp. and shall not be distributed, reproduced, or disclosed in whole or in part without prior written permission of ILI Technology Corp.

R6Ah	W	1	0	0	0	0	0	0	0	0	VL8	VL7	VL6	VL5	VL4	VL3	VL2	VL1	VL0
------	---	---	---	---	---	---	---	---	---	---	-----	-----	-----	-----	-----	-----	-----	-----	-----

SCN[5:0] The ILI9325 allows to specify the gate line from which the gate driver starts to scan by setting the SCN[5:0] bits.

SCN[5:0]	Scanning Start Position			
	SM=0		SM=1	
	GS=0	GS=1	GS=0	GS=1
00h	G1	G320	G1	G320
01h	G9	G312	G17	G304
02h	G17	G304	G33	G288
03h	G25	G296	G49	G272
04h	G33	G288	G65	G256
05h	G41	G280	G81	G240
06h	G49	G272	G97	G224
07h	G57	G264	G113	G208
08h	G65	G256	G129	G192
09h	G73	G248	G145	G176
0Ah	G81	G240	G161	G160
0Bh	G89	G232	G177	G144
0Ch	G97	G224	G193	G128
0Dh	G105	G216	G209	G112
0Eh	G113	G208	G2	G96
0Fh	G121	G200	G18	G80
10h	G129	G192	G34	G64
11h	G137	G184	G50	G48
12h	G145	G176	G66	G32
13h	G153	G168	G82	G16
14h	G161	G160	G98	G319
15h	G169	G152	G114	G303
16h	G177	G144	G130	G287
17h	G185	G136	G146	G271
18h	G193	G128	G162	G255
19h	G201	G120	G178	G239
1Ah	G209	G112	G194	G223
1Bh	G217	G104	G114	G207
1Ch	G225	G96	G130	G191
1Dh	G233	G88	G146	G175
1Eh	G241	G80	G162	G159
1Fh	G249	G72	G178	G143
20h	G257	G64	G194	G127
21h	G265	G56	G210	G111
22h	G273	G48	G226	G95
23h	G281	G40	G242	G79
24h	G289	G32	G258	G63
25h	G297	G24	G274	G47
26h	G305	G16	G290	G31
27h	G313	G8	G306	G15
28h ~ 3Fh	Setting disabled	Setting disabled	Setting disabled	Setting disabled

NL[5:0]: Sets the number of lines to drive the LCD at an interval of 8 lines. The GRAM address mapping is not affected by the number of lines set by NL[5:0]. The number of lines must be the same or more than the number of lines necessary for the size of the liquid crystal panel.

NL[5:0]	LCD Drive Line
6'h1D	240 lines
6'h1E	248 lines
6'h1F	256 lines
6'h20	264 lines
6'h21	272 lines
6'h22	280 lines
6'h23	288 lines
6'h24	296 lines
6'h25	304 lines
6'h26	312 line
6'h27	320 line
Others	Setting inhibited

NDL: Sets the source driver output level in the non-display area.

NDL	Non-Display Area	
	Positive Polarity	Negative Polarity
0	V63	V0
1	V0	V63

GS: Sets the direction of scan by the gate driver in the range determined by SCN[4:0] and NL[4:0]. The scan direction determined by GS = 0 can be reversed by setting GS = 1.

When GS = 0, the scan direction is from G1 to G320.

When GS = 1, the scan direction is from G320 to G1

REV: Enables the grayscale inversion of the image by setting REV=1.

REV	GRAM Data	Source Output in Display Area	
		Positive polarity	negative polarity
0	18'h00000	V63	V0
	.	.	.
	18'h3FFFF	V0	V63
1	18'h00000	V0	V63
	.	.	.
	18'h3FFFF	V63	V0

VLE: Vertical scroll display enable bit. When VLE = 1, the ILI9325 starts displaying the base image from the line (of the physical display) determined by VL[8:0] bits. VL[8:0] sets the amount of scrolling, which is the number of lines to shift the start line of the display from the first line of the physical display. Note that the partial image display position is not affected by the base image scrolling.

The vertical scrolling is not available in external display interface operation. In this case, make sure to set VLE = "0".

VLE	Base Image Display
0	Fixed
1	Enable Scrolling

VL[8:0]: Sets the scrolling amount of base image. The base image is scrolled in vertical direction and displayed from the line determined by VL[8:0]. Make sure that VL[8:0] \leq 320.

8.2.26. Partial Image 1 Display Position (R80h)

R/W	RS	D15	D14	D13	D12	D11	D10	D9	D8	D7	D6	D5	D4	D3	D2	D1	D0
W	1	0	0	0	0	0	0	0	PTD	PTD	PTD	PTD	PTD	PTD	PTD	PTD	PTD
									P0[8]	P0[7]	P0[6]	P0[5]	P0[4]	P0[3]	P0[2]	P0[1]	P0[0]

PTDP0[8:0]: Sets the display start position of partial image 1. The display areas of the partial images 1 and 2 must not overlap each another.

8.2.27. Partial Image 1 RAM Start/End Address (R81h, R82h)

R/W	RS	D15	D14	D13	D12	D11	D10	D9	D8	D7	D6	D5	D4	D3	D2	D1	D0
W	1	0	0	0	0	0	0	0	PTS	PTS	PTS	PTS	PTS	PTS	PTS	PTS	PTS
									A0[8]	A0[7]	A0[6]	A0[5]	A0[4]	A0[3]	A0[2]	A0[1]	A0[0]
W	1	0	0	0	0	0	0	0	PTE	PTE	PTE	PTE	PTE	PTE	PTE	PTE	PTE
									A0[8]	A0[7]	A0[6]	A0[5]	A0[4]	A0[3]	A0[2]	A0[1]	A0[0]

PTSA0[8:0] PTEA0[8:0]: Sets the start line address and the end line address of the RAM area storing the data of partial image 1. Make sure PTSA0[8:0] \leq PTEA0[8:0].

8.2.28. Partial Image 2 Display Position (R83h)

R/W	RS	D15	D14	D13	D12	D11	D10	D9	D8	D7	D6	D5	D4	D3	D2	D1	D0
W	1	0	0	0	0	0	0	0	PTD	PTD	PTD	PTD	PTD	PTD	PTD	PTD	PTD
									P1[8]	P1[7]	P1[6]	P1[5]	P1[4]	P1[3]	P1[2]	P1[1]	P1[0]

PTDP1[8:0]: Sets the display start position of partial image 2. The display areas of the partial images 1 and 2 must not overlap each another.

8.2.29. Partial Image 2 RAM Start/End Address (R84h, R85h)

R/W	RS	D15	D14	D13	D12	D11	D10	D9	D8	D7	D6	D5	D4	D3	D2	D1	D0
W	1	0	0	0	0	0	0	0	PTS	PTS	PTS	PTS	PTS	PTS	PTS	PTS	PTS
									A1[8]	A1[7]	A1[6]	A1[5]	A1[4]	A1[3]	A1[2]	A1[1]	A1[0]
W	1	0	0	0	0	0	0	0	PTE	PTE	PTE	PTE	PTE	PTE	PTE	PTE	PTE
									A1[8]	A1[7]	A1[6]	A1[5]	A1[4]	A1[3]	A1[2]	A1[1]	A1[0]

PTSA1[8:0] PTEA1[8:0]: Sets the start line address and the end line address of the RAM area storing the data of partial image 2. Make sure PTSA1[8:0] \leq PTEA1[8:0].

8.2.30. Panel Interface Control 1 (R90h)

R/W	RS	D15	D14	D13	D12	D11	D10	D9	D8	D7	D6	D5	D4	D3	D2	D1	D0
W	1	0	0	0	0	0	0	DIV1	DIV0	0	0	0	RTNI4	RTNI3	RTNI2	RTNI1	RTNI0

RTNI[4:0]: Sets 1H (line) clock number of internal clock operating mode. In this mode, ILI9325 display operation is synchronized with internal clock signal.

RTNI[4:0]	Clocks/Line	RTNI[4:0]	Clocks/Line
00000~01111	Setting Disabled	11000	24 clocks
10000	16 clocks	11001	25 clocks
10001	17 clocks	11010	26 clocks
10010	18 clocks	11011	27 clocks
10011	19 clocks	11100	28 clocks
10100	20 clocks	11101	29 clocks
10101	21 clocks	11110	30 clocks
10110	22 clocks	11111	31 clocks
10111	23 clocks		

DIV1[1:0]: Sets the division ratio of internal clock frequency.

DIV1	DIV0	Division Ratio	Internal Operation Clock Frequency
0	0	1	fosc / 1
0	1	2	fosc / 2
1	0	4	fosc / 4
1	1	8	fosc / 8

8.2.31. Panel Interface Control 2 (R92h)

R/W	RS	D15	D14	D13	D12	D11	D10	D9	D8	D7	D6	D5	D4	D3	D2	D1	D0
W	1	0	0	0	0	0	NOWI[2]	NOWI[1]	NOWI[0]	0	0	0	0	0	0	0	0

NOWI[2:0]: Sets the gate output non-overlap period when ILI9325 display operation is synchronized with internal clock signal.

NOWI[2:0]	Gate Non-overlap Period
000	0 clocks
001	1 clocks
010	2 clocks
011	3 clocks
100	4 clocks
101	5 clocks
110	6 clocks
111	7 clocks

Note: The gate output non-overlap period is defined by the number of frequency-divided internal clocks, the frequency of which is determined by instruction (DIV1), from the reference point.

8.2.32. Panel Interface Control 4 (R95h)

R/W	RS	D15	D14	D13	D12	D11	D10	D9	D8	D7	D6	D5	D4	D3	D2	D1	D0
W	1	0	0	0	0	0	0	DIVE1	DIVE0	0	0	RTNE5	RTNE4	RTNE3	RTNE2	RTNE1	RTNE0

RTNE[5:0]: Sets 1H (line) clock number of RGB interface mode. In this mode, ILI9325 display operation is synchronized with RGB interface signals.

$DIVE$ (division ratio) \times $RTNE$ (DOTCLKs) \leq DOTCLKs in 1H period.

RTNE[5:0]	Clocks per line period (1H)	RTNE[5:0]	Clocks per line period (1H)	RTNE[5:0]	Clocks per line period (1H)	RTNE[5:0]	Clocks per line period (1H)
00h	Setting Prohibited	10h	16 clocks	20h	32 clocks	30h	48 clocks
01h	Setting Prohibited	11h	17 clocks	21h	33 clocks	31h	49 clocks
02h	Setting Prohibited	12h	18 clocks	22h	34 clocks	32h	50 clocks
03h	Setting Prohibited	13h	19 clocks	23h	35 clocks	33h	51 clocks
04h	Setting Prohibited	14h	20 clocks	24h	36 clocks	34h	52 clocks
05h	Setting Prohibited	15h	21 clocks	25h	37 clocks	35h	53 clocks
06h	Setting Prohibited	16h	22 clocks	26h	38 clocks	36h	54 clocks
07h	Setting Prohibited	17h	23 clocks	27h	39 clocks	37h	55 clocks
08h	Setting Prohibited	18h	24 clocks	28h	40 clocks	38h	56 clocks
09h	Setting Prohibited	19h	25 clocks	29h	41 clocks	39h	57 clocks
0ah	Setting Prohibited	1ah	26 clocks	2ah	42 clocks	3ah	58 clocks
0bh	Setting Prohibited	1bh	27 clocks	2bh	43 clocks	3bh	59 clocks
0ch	Setting Prohibited	1ch	28 clocks	2ch	44 clocks	3ch	60 clocks
0dh	Setting Prohibited	1dh	29 clocks	2dh	45 clocks	3dh	61 clocks
0eh	Setting Prohibited	1eh	30 clocks	2eh	46 clocks	3eh	62 clocks
0fh	Setting Prohibited	1fh	31 clocks	2fh	47 clocks	3fh	63 clocks

DIVE[1:0]: Sets the division ratio of DOTCLK when ILI9325 display operation is synchronized with RGB interface signals.

DIVE[1:0]	Division Ratio	18/16-bit RGB Interface	DOTCLK=5MHz	6-bit x 3 Transfers RGB Interface	DOTCLK=5MHz
00	Setting Prohibited	Setting Prohibited	-	Setting Prohibited	-
01	1/4	4 DOTCLKS	0.8 μ s	12 DOTCLKS	0.8 μ s
10	1/8	8 DOTCLKS	1.6 μ s	24 DOTCLKS	1.6 μ s
11	1/16	16 DOTCLKS	3.2 μ s	48 DOTCLKS	3.2 μ s

8.2.33. OTP VCM Programming Control (RA1h)

R/W	RS	D15	D14	D13	D12	D11	D10	D9	D8	D7	D6	D5	D4	D3	D2	D1	D0
W	1	0	0	0	0	OTP_PGM_EN	0	0	0	0	0	VCM_OTP5	VCM_OTP4	VCM_OTP3	VCM_OTP2	VCM_OTP1	VCM_OTP0

OTP_PGM_EN: OTP programming enable. When program OTP, must set this bit. OTP data can be programmed 3 times.

VCM_OTP[5:0]: OTP programming data for VCOMH voltage, the voltage refer to VCM[5:0] value.

8.2.34. OTP VCM Status and Enable (RA2h)

R/W	RS	D15	D14	D13	D12	D11	D10	D9	D8	D7	D6	D5	D4	D3	D2	D1	D0
W	1	PGM_CNT1	PGM_CNT0	VCM_D5	VCM_D4	VCM_D3	VCM_D2	VCM_D1	VCM_D0	0	0	0	0	0	0	0	VCM_EN

PGM_CNT[1:0]: OTP programmed record. These bits are read only.

OTP_PGM_CNT[1:0]	Description
00	OTP clean
01	OTP programmed 1 time
10	OTP programmed 2 times
11	OTP programmed 3 times

VCM_D[5:0]: OTP VCM data read value. These bits are read only.

VCM_EN: OTP VCM data enable.

'1': Set this bit to enable OTP VCM data to replace R29h VCM value.

'0': Default value, use R29h VCM value.

8.2.35. OTP Programming ID Key (RA5h)

R/W	RS	D15	D14	D13	D12	D11	D10	D9	D8	D7	D6	D5	D4	D3	D2	D1	D0
W	1	KEY 15	KEY 14	KEY 13	KEY 12	KEY 11	KEY 10	KEY 9	KEY 8	KEY 7	KEY 6	KEY 5	KEY 4	KEY 3	KEY 2	KEY 1	KEY 0

KEY[15:0]: OTP Programming ID key protection. Before writing OTP programming data RA1h, it must write RA5h with 0xAA55 value first to make OTP programming successfully. If RA5h is not written with 0xAA55, OTP programming will be fail. See OTP Programming flow.

9. OTP Programming Flow

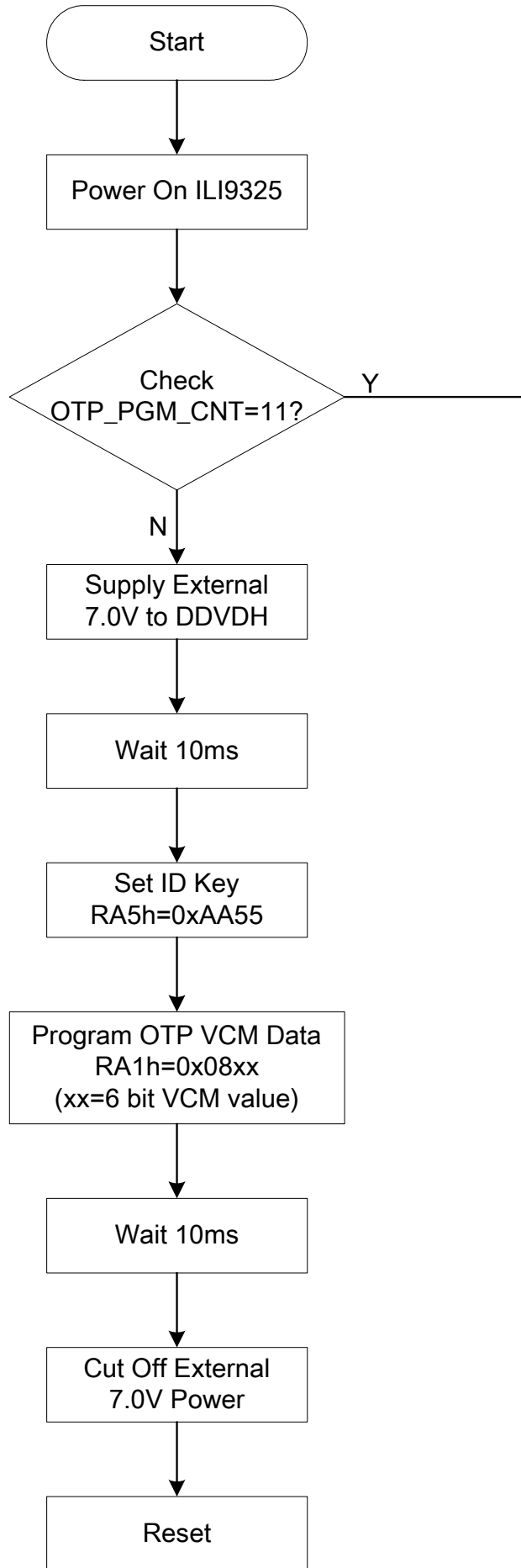

10. GRAM Address Map & Read/Write

ILI9325 has an internal graphics RAM (GRAM) of 87,120 bytes to store the display data and one pixel is constructed of 18 bits. The GRAM can be accessed through the i80 system, SPI and RGB interfaces.

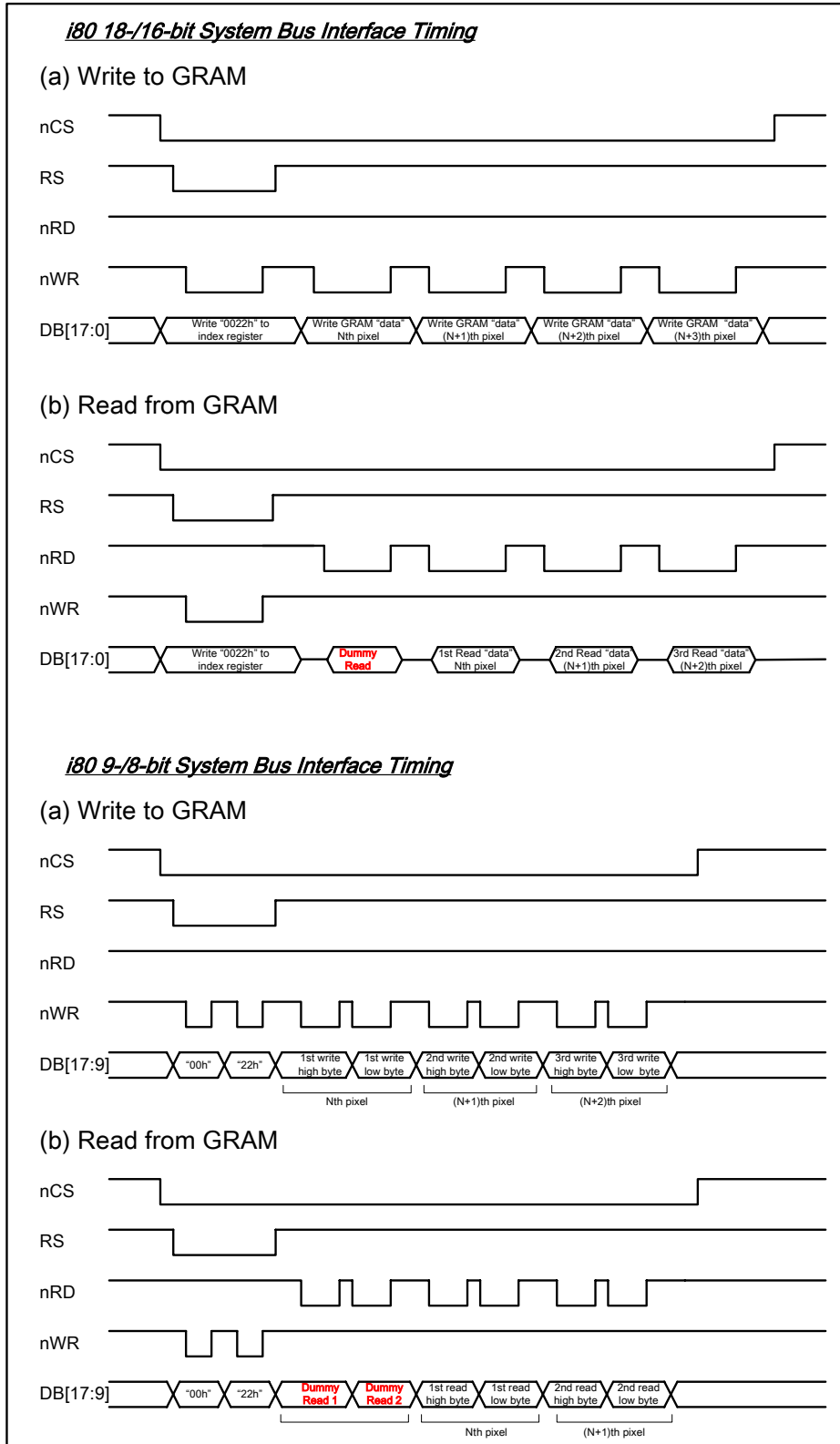
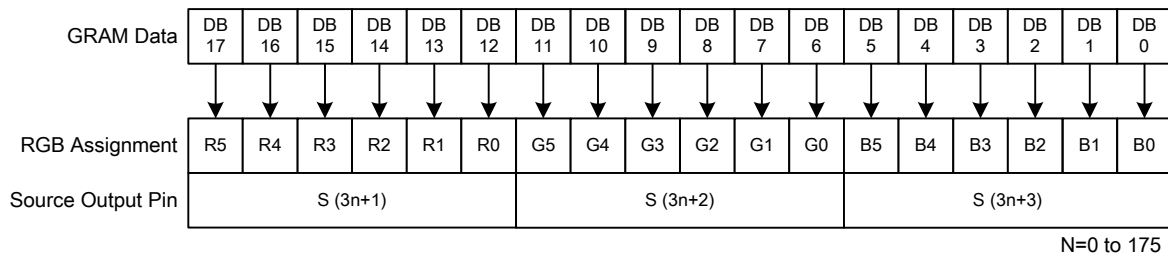

Figure33 GRAM Read/Write Timing of i80-System Interface

GRAM address map table of SS=0, BGR=0

SS=0, BGR=0		S1...S3	S4...S6	S7...S9	S10...S12	...	S517...S519	S520...S522	S523...S525	S526...S720
GS=0	GS=1	DB17...0	DB17...0	DB17...0	DB17...0	...	DB17...0	DB17...0	DB17...0	DB17...0
G1	G320	"00000h"	"00001h"	"00002h"	"00003h"	...	"000ECh"	"000EDh"	"000EEh"	"000EFh"
G2	G319	"00100h"	"00101h"	"00102h"	"00103h"	...	"001ECh"	"001EDh"	"001EEh"	"001EFh"
G3	G318	"00200h"	"00201h"	"00202h"	"00203h"	...	"002ECh"	"002EDh"	"002EEh"	"002EFh"
G4	G317	"00300h"	"00301h"	"00302h"	"00303h"	...	"003ECh"	"003EDh"	"003EEh"	"003EFh"
G5	G316	"00400h"	"00401h"	"00402h"	"00403h"	...	"004ECh"	"004EDh"	"004EEh"	"004EFh"
G6	G315	"00500h"	"00501h"	"00502h"	"00503h"	...	"005ECh"	"005EDh"	"005EEh"	"005EFh"
G7	G314	"00600h"	"00601h"	"00602h"	"00603h"	...	"006ECh"	"006EDh"	"006EEh"	"006EFh"
G8	G313	"00700h"	"00701h"	"00702h"	"00703h"	...	"007ECh"	"007EDh"	"007EEh"	"007EFh"
G9	G312	"00800h"	"00801h"	"00802h"	"00803h"	...	"008ECh"	"008EDh"	"008EEh"	"008EFh"
G10	G311	"00900h"	"00901h"	"00902h"	"00903h"	...	"009ECh"	"009EDh"	"009EEh"	"009EFh"
.
.
.
G311	G10	"13600h"	"13601h"	"13602h"	"13603h"	...	"136ECh"	"136EDh"	"136EEh"	"136EFh"
G312	G9	"13700h"	"13701h"	"13702h"	"13703h"	...	"137ECh"	"137EDh"	"137EEh"	"137EFh"
G313	G8	"13800h"	"13801h"	"13802h"	"13803h"	...	"138ECh"	"138EDh"	"138EEh"	"138EFh"
G314	G7	"13900h"	"13901h"	"13902h"	"13903h"	...	"139ECh"	"139EDh"	"139EEh"	"139EFh"
G315	G6	"13A00h"	"13A01h"	"13A02h"	"13A03h"	...	"13AECh"	"13AEDh"	"13AEEh"	"13AEFh"
G316	G5	"13B00h"	"13B01h"	"13B02h"	"13B03h"	...	"13BECh"	"13BEDh"	"13BEEh"	"13BEFh"
G317	G4	"13C00h"	"13C01h"	"13C02h"	"13C03h"	...	"13CECh"	"13CEDh"	"13CEEh"	"13CEFh"
G318	G3	"13D00h"	"13D01h"	"13D02h"	"13D03h"	...	"13DECh"	"13DEDh"	"13DEEh"	"13DEFh"
G319	G2	"13E00h"	"13E01h"	"13E02h"	"13E03h"	...	"13EECh"	"13EEDh"	"13EEEh"	"13EEFh"
G320	G1	"13F00h"	"13F01h"	"13F02h"	"13F03h"	...	"13FECh"	"13FEDh"	"13FEEh"	"13FEFh"

i80/M68 system 18-bit data bus interface



i80/M68 system 16-bit data bus interface

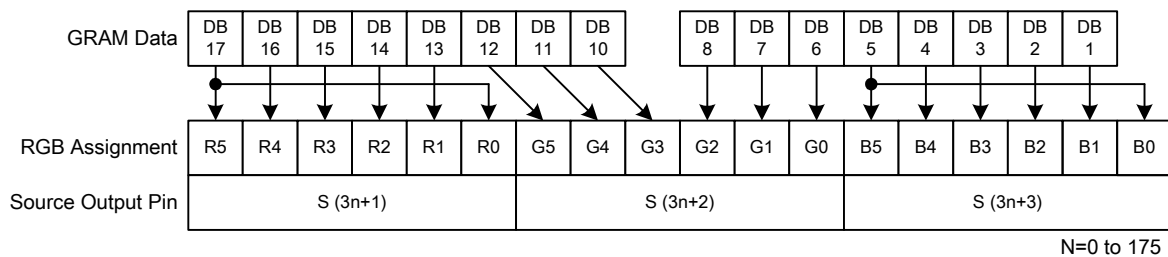

i80/M68 system 9-bit data bus interface

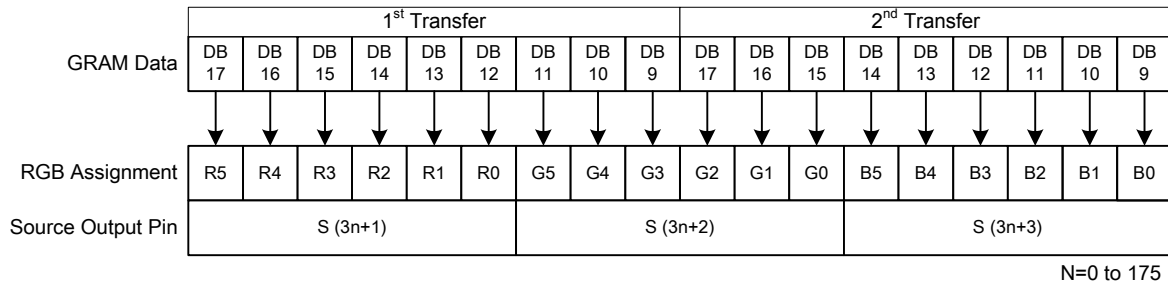

GRAM Data and display data of 18-/16-/9-bit system interface (SS="0", BGR="0")

Figure34 i80-System Interface with 18-/16-/9-bit Data Bus (SS="0", BGR="0")

i80/M68 system 8-bit interface / SPI Interface (2 transfers/pixel)

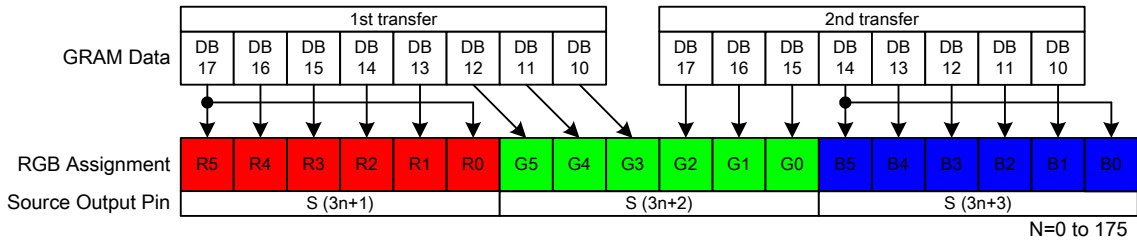

i80/M68 system 8-bit interface (3 transfers/pixel, TRI="1", DFM[1:0]="00")

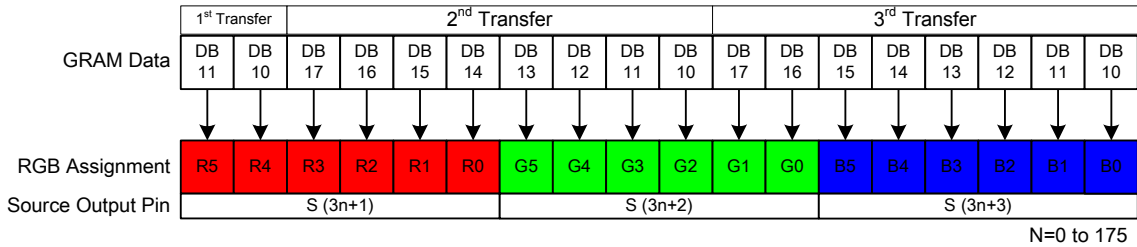

i80/M68 system 8-bit interface (3 transfers/pixel, TRI="1", DFM[1:0]="10")

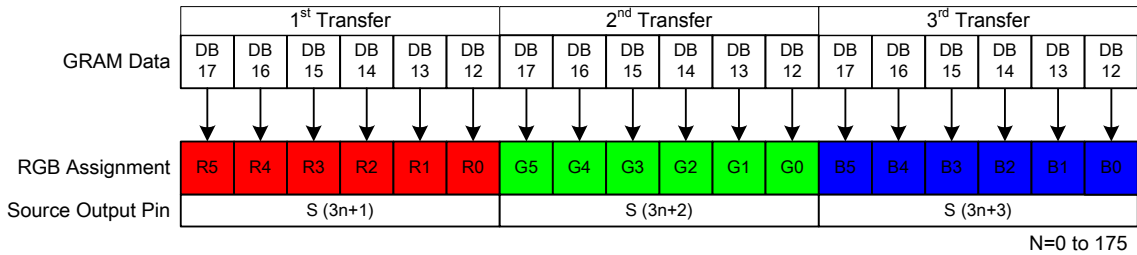

i80/M68 system 8-bit interface (SS="0", BGR="0")

Figure35 i80-System Interface with 8-bit Data Bus (SS="0", BGR="0")

GRAM address map table of SS=1, BGR=1

SS=0, BGR=0	S720...S718	S717...S715	S714...S712	S711...S709	...	S12...S10	S9...S7	S6...S4	S3...S1	
GS=0	GS=1	DB17...0	DB17...0	DB17...0	DB17...0	...	DB17...0	DB17...0	DB17...0	DB17...0
G1	G320	"00000h"	"00001h"	"00002h"	"00003h"	...	"000ECh"	"000EDh"	"000EEh"	"000EFh"
G2	G319	"00100h"	"00101h"	"00102h"	"00103h"	...	"001ECh"	"001EDh"	"001EEh"	"001EFh"
G3	G318	"00200h"	"00201h"	"00202h"	"00203h"	...	"002ECh"	"002EDh"	"002EEh"	"002EFh"
G4	G317	"00300h"	"00301h"	"00302h"	"00303h"	...	"003ECh"	"003EDh"	"003EEh"	"003EFh"
G5	G316	"00400h"	"00401h"	"00402h"	"00403h"	...	"004ECh"	"004EDh"	"004EEh"	"004EFh"
G6	G315	"00500h"	"00501h"	"00502h"	"00503h"	...	"005ECh"	"005EDh"	"005EEh"	"005EFh"
G7	G314	"00600h"	"00601h"	"00602h"	"00603h"	...	"006ECh"	"006EDh"	"006EEh"	"006EFh"
G8	G313	"00700h"	"00701h"	"00702h"	"00703h"	...	"007ECh"	"007EDh"	"007EEh"	"007EFh"
G9	G312	"00800h"	"00801h"	"00802h"	"00803h"	...	"008ECh"	"008EDh"	"008EEh"	"008EFh"
G10	G311	"00900h"	"00901h"	"00902h"	"00903h"	...	"009ECh"	"009EDh"	"009EEh"	"009EFh"
.
.
.
G311	G10	"13600h"	"13601h"	"13602h"	"13603h"	...	"136ECh"	"136EDh"	"136EEh"	"136EFh"
G312	G9	"13700h"	"13701h"	"13702h"	"13703h"	...	"137ECh"	"137EDh"	"137EEh"	"137EFh"
G313	G8	"13800h"	"13801h"	"13802h"	"13803h"	...	"138ECh"	"138EDh"	"138EEh"	"138EFh"
G314	G7	"13900h"	"13901h"	"13902h"	"13903h"	...	"139ECh"	"139EDh"	"139EEh"	"139EFh"
G315	G6	"13A00h"	"13A01h"	"13A02h"	"13A03h"	...	"13AECh"	"13AEDh"	"13AEEh"	"13AEFh"
G316	G5	"13B00h"	"13B01h"	"13B02h"	"13B03h"	...	"13BECh"	"13BEDh"	"13BEEh"	"13BEFh"
G317	G4	"13C00h"	"13C01h"	"13C02h"	"13C03h"	...	"13CECh"	"13CEDh"	"13CEEh"	"13CEFh"
G318	G3	"13D00h"	"13D01h"	"13D02h"	"13D03h"	...	"13DECh"	"13DEDh"	"13DEEh"	"13DEFh"
G319	G2	"13E00h"	"13E01h"	"13E02h"	"13E03h"	...	"13EECh"	"13EEDh"	"13EEEh"	"13EEFh"
G320	G1	"13F00h"	"13F01h"	"13F02h"	"13F03h"	...	"13FECh"	"13FEDh"	"13FEEh"	"13FEFh"

i80/M68 system 18-bit data bus interface

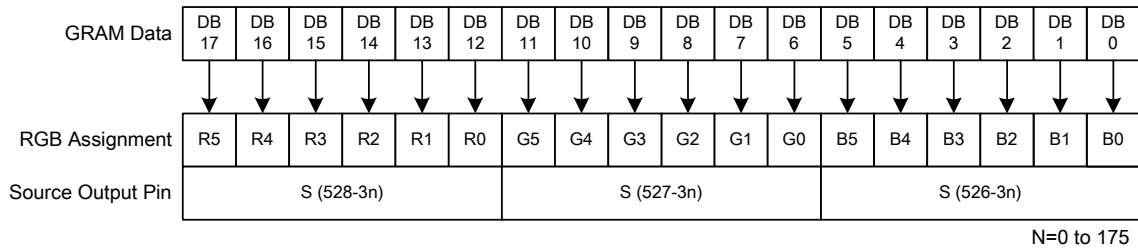

i80/M68 system 9-bit data bus interface

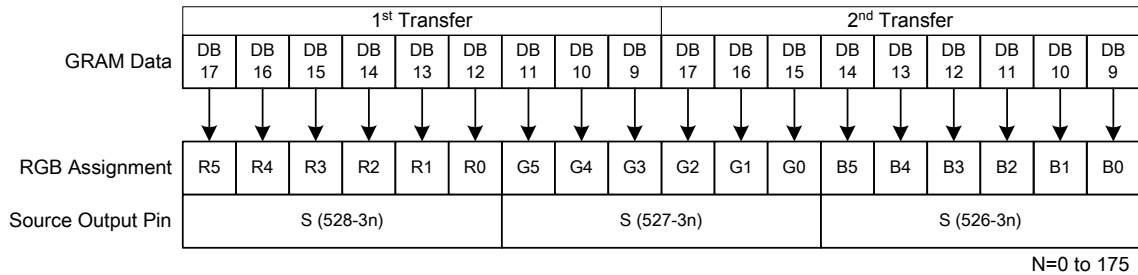

GRAM Data and display data of 18-/9-bit system interface (SS="1", BGR="1")

Figure 36 i80-System Interface with 18-/9-bit Data Bus (SS="1", BGR="1")

11. Window Address Function

The window address function enables writing display data consecutively in a rectangular area (a window address area) made on the internal RAM. The window address area is made by setting the horizontal address register (start: HSA[7:0], end: HEA[7:0] bits) and the vertical address register (start: VSA[8:0], end: VEA[8:0] bits). The AM bit sets the transition direction of RAM address (either increment or decrement). These bits enable the ILI9325 to write data including image data consecutively not taking data wrap positions into account.

The window address area must be made within the GRAM address map area. Also, the GRAM address bits (RAM address set register) must be an address within the window address area.

[Window address setting area]

(Horizontal direction) $00H \leq HSA[7:0] \leq HEA[7:0] \leq "EF"H$

(Vertical direction) $00H \leq VSA[8:0] \leq VEA[8:0] \leq "13F"H$

[RAM address, AD (an address within a window address area)]

(RAM address) $HSA[7:0] \leq AD[7:0] \leq HEA[7:0]$

$VSA[8:0] \leq AD[15:8] \leq VEA[8:0]$

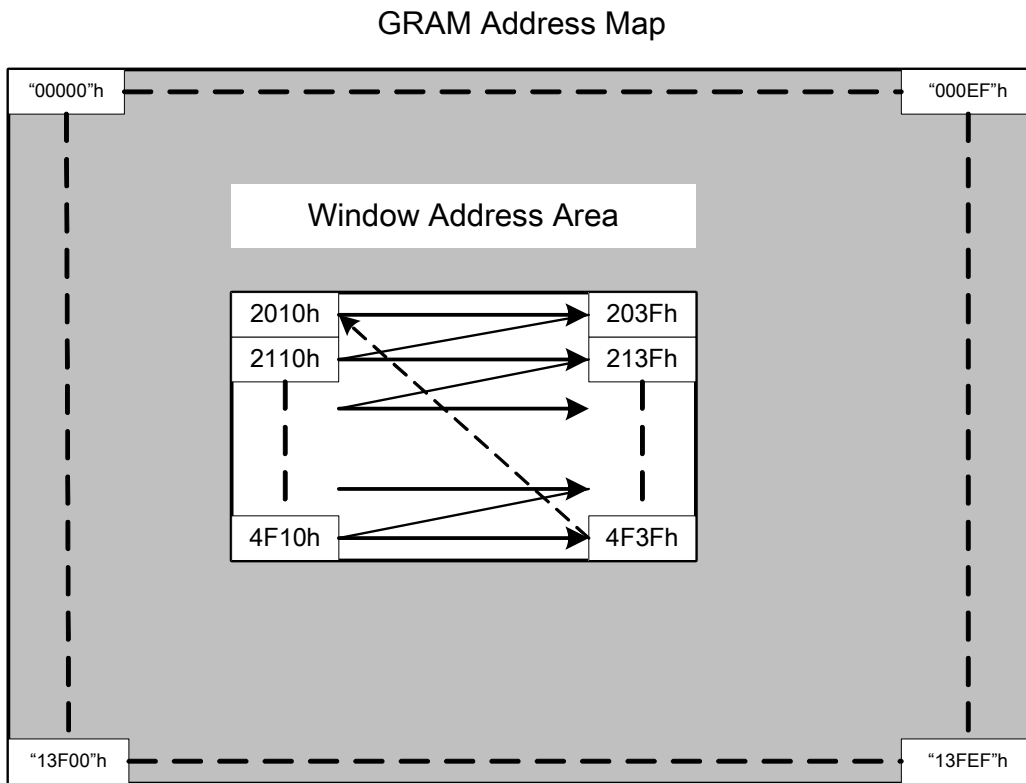

Window address setting area

HSA[7:0] = 10h, HSA[7:0] = 3Fh, I/D = 1 (increment)
VSA[8:0] = 20h, VSA[8:0] = 4Fh, AM = 0 (horizontal writing)

Figure 37 GRAM Access Window Map

12. Gamma Correction

ILI9325 incorporates the γ -correction function to display 262,144 colors for the LCD panel. The γ -correction is performed with 3 groups of registers determining eight reference grayscale levels, which are gradient adjustment, amplitude adjustment and fine-adjustment registers for positive and negative polarities, to make ILI9325 available with liquid crystal panels of various characteristics.

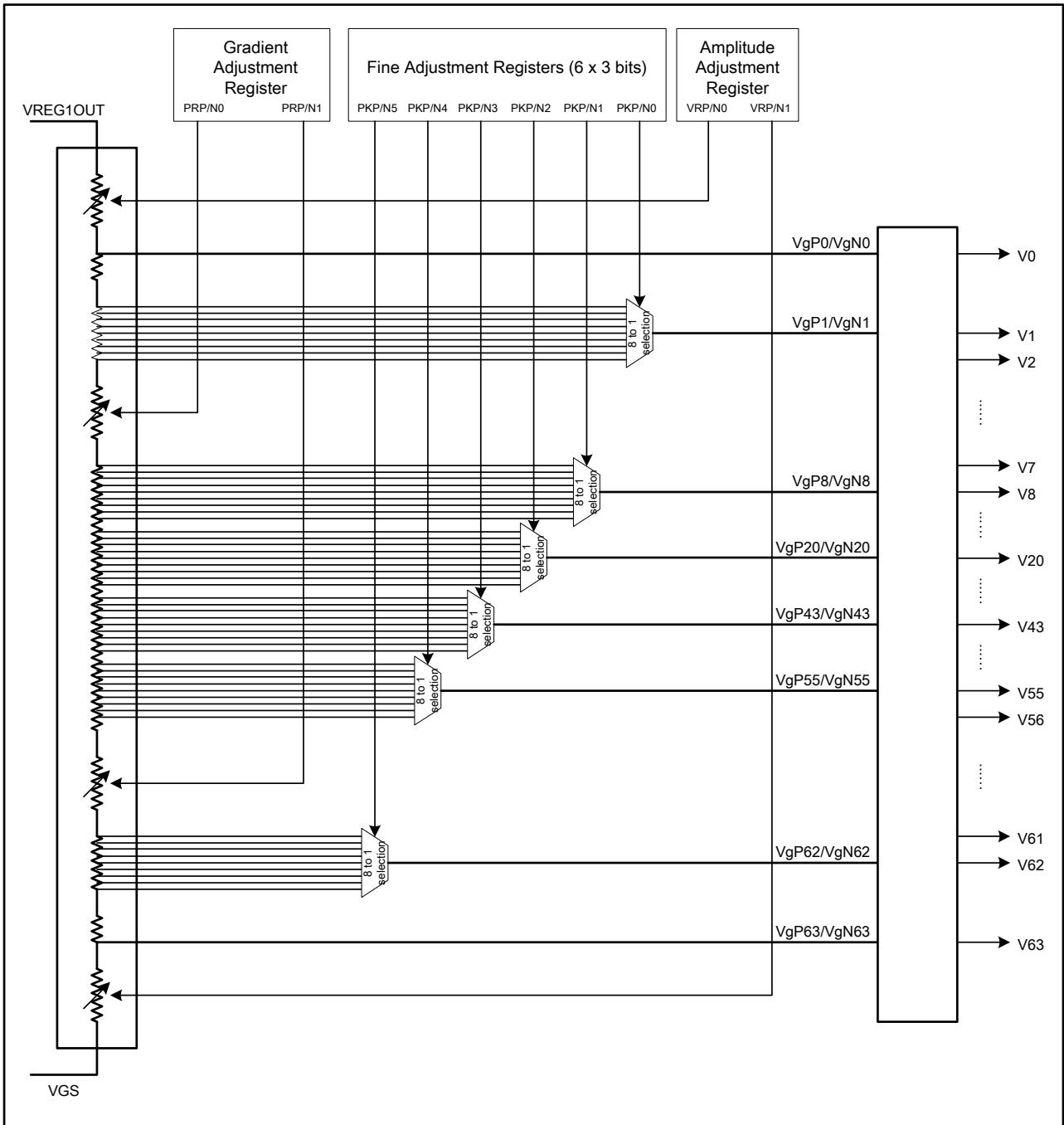

Figure 38 Grayscale Voltage Generation

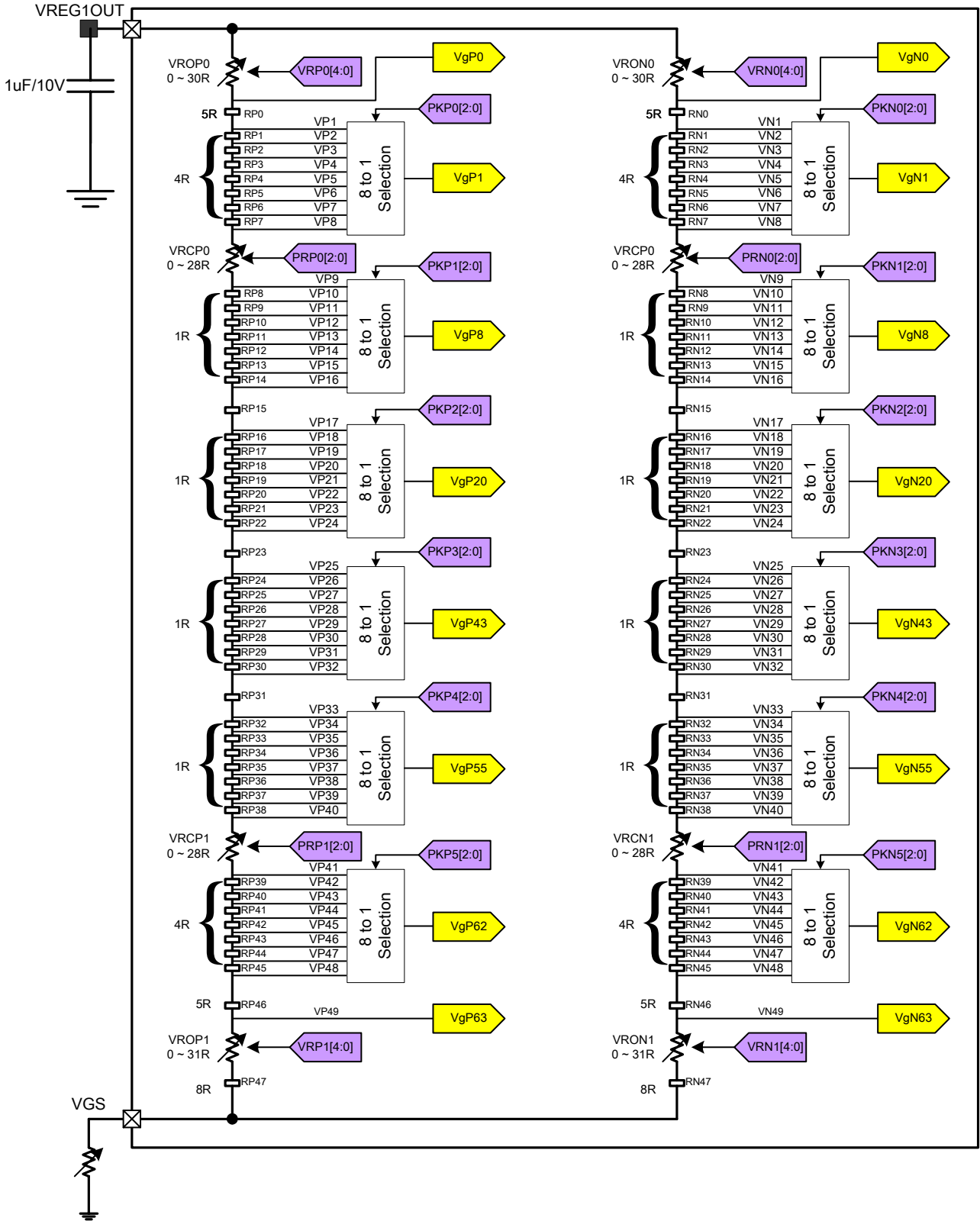

Figure 39 Grayscale Voltage Adjustment

1. Gradient adjustment registers

The gradient adjustment registers are used to adjust the gradient of the curve representing the relationship between the grayscale and the grayscale reference voltage level. To adjust the gradient, the resistance values of variable resistors in the middle of the ladder resistor are adjusted by registers PRP0[2:0]/PRN0[2:0], PRP1[2:0]/PRN1[2:0]. The registers consist of positive and negative polarity registers, allowing asymmetric drive.

2. Amplitude adjustment registers

The amplitude adjustment registers, VRP0[3:0]/VRN0[3:0], VRP1[4:0]/VRN1[4:0], are used to adjust the amplitude of grayscale voltages. To adjust the amplitude, the resistance values of variable resistors at the top and bottom of the ladder resistor are adjusted. Same as the gradient registers, the amplitude adjustment registers consist of positive and negative polarity registers.

3. Fine adjustment registers

The fine adjustment registers are used to fine-adjust grayscale voltage levels. To fine-adjust grayscale voltage levels, fine adjustment registers adjust the reference voltage levels, 8 levels for each register generated from the ladder resistor, in respective 8-to-1 selectors. Same with other registers, the fine adjustment registers consist of positive and negative polarity registers.

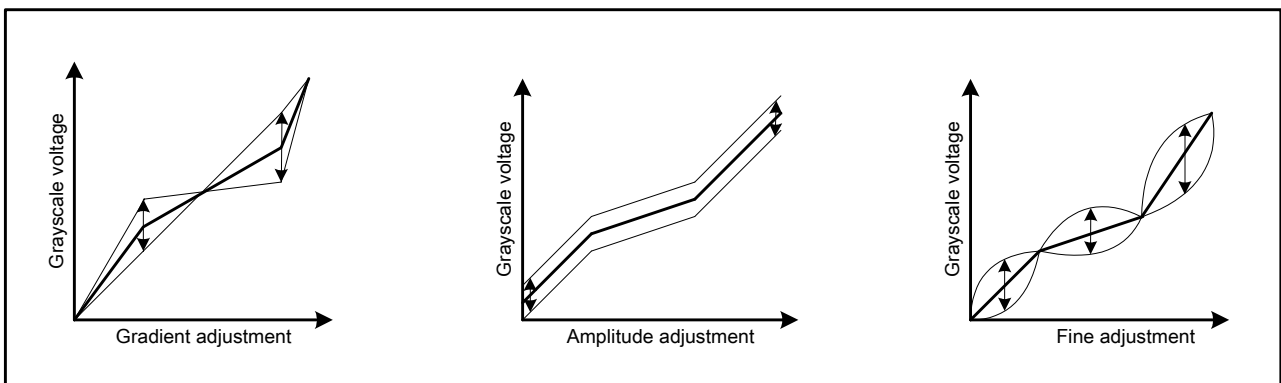

Figure 40 Gamma Curve Adjustment

Register Groups	Positive Polarity	Negative Polarity	Description
Gradient adjustment	PRP0 [2:0]	PRN0 [2:0]	Variable resistor VRCP0, VRCN0
	PRP1 [2:0]	PRN1 [2:0]	Variable resistor VRCP1, VRCN1
Amplitude adjustment	VRP0 [3:0]	VRN0 [3:0]	Variable resistor VROP0, VRON0
	VRP1 [4:0]	VRN1 [4:0]	Variable resistor VROP1, VRON1
Fine adjustment	KP0 [2:0]	KN0 [2:0]	8-to-1 selector (voltage level of grayscale 1)
	KP1 [2:0]	KN1 [2:0]	8-to-1 selector (voltage level of grayscale 8)
	KP2 [2:0]	KN2 [2:0]	8-to-1 selector (voltage level of grayscale 20)
	KP3 [2:0]	KN3 [2:0]	8-to-1 selector (voltage level of grayscale 43)
	KP4 [2:0]	KN4 [2:0]	8-to-1 selector (voltage level of grayscale 55)
	KP5 [2:0]	KN5 [2:0]	8-to-1 selector (voltage level of grayscale 62)

Ladder resistors and 8-to-1 selector Block configuration

The reference voltage generating block consists of two ladder resistor units including variable resistors and 8-to-1 selectors. Each 8-to-1 selector selects one of the 8 voltage levels generated from the ladder resistor unit to output as a grayscale reference voltage. Both variable resistors and 8-to-1 selectors are controlled according to the γ -correction registers. This unit has pins to connect a volume resistor externally to compensate differences in various characteristics of panels.

Variable resistors

ILI9325 uses variable resistors of the following three purposes: gradient adjustment (VRCP(N)0/VRCP(N)1); amplitude adjustment (1) (VROP(N)0); and the amplitude adjustment (2) (VROP(N)1). The resistance values of these variable resistors are set by gradient adjustment registers and amplitude adjustment registers as follows.

Gradient adjustment		Amplitude adjustment (1)		Amplitude adjustment (2)	
PRP(N)0/1[2:0]	VRCP(N)0	VRP(N)0[3:0]	VROP(N)0	VRP(N)1[4:0]	VROP(N)1
Register	Resistance	Register	Resistance	Register	Resistance
000	0R	0000	0R	00000	0R
001	4R	0001	2R	00001	1R
010	8R	0010	4R	00010	2R
011	12R	:	:	:	:
100	16R	:	:	:	:
101	20R	1101	26R	11101	29R
110	24R	1111	28R	11110	30R
111	28R	1111	30R	11111	31R

8-to-1 selectors

The 8-to-1 selector selects one of eight voltage levels generated from the ladder resistor unit according to the fine adjustment register and output the selected voltage level as a reference grayscale voltage (VgP(N)1~6). The table below shows the setting in the fine adjustment register and the selected voltage levels for respective reference grayscale voltages.

Fine adjustment registers and selected voltage						
Register	Selected Voltage					
KP(N)[2:0]	VgP(N)1	VgP(N)8	VgP(N)20	VgP(N)43	VgP(N)55	VgP(N)62
000	VP(N)1	VP(N)9	VP(N)17	VP(N)25	VP(N)33	VP(N)41
001	VP(N)2	VP(N)10	VP(N)18	VP(N)26	VP(N)34	VP(N)42
010	VP(N)3	VP(N)11	VP(N)19	VP(N)27	VP(N)35	VP(N)43
011	VP(N)4	VP(N)12	VP(N)20	VP(N)28	VP(N)36	VP(N)44
100	VP(N)5	VP(N)13	VP(N)21	VP(N)29	VP(N)37	VP(N)45
101	VP(N)6	VP(N)14	VP(N)22	VP(N)30	VP(N)38	VP(N)46
110	VP(N)7	VP(N)15	VP(N)23	VP(N)31	VP(N)39	VP(N)47
111	VP(N)8	VP(N)16	VP(N)24	VP(N)32	VP(N)40	VP(N)48

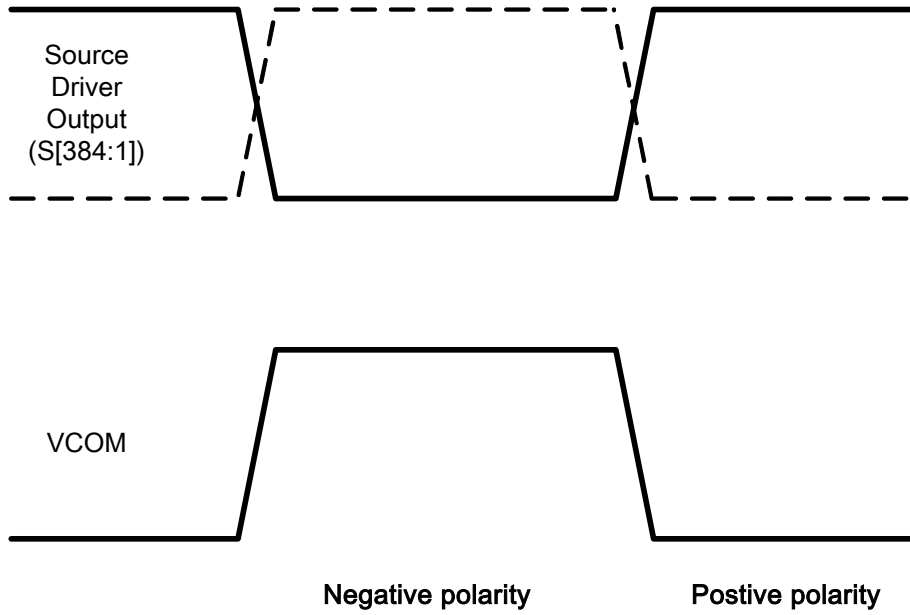

Figure 41 Relationship between Source Output and VCOM

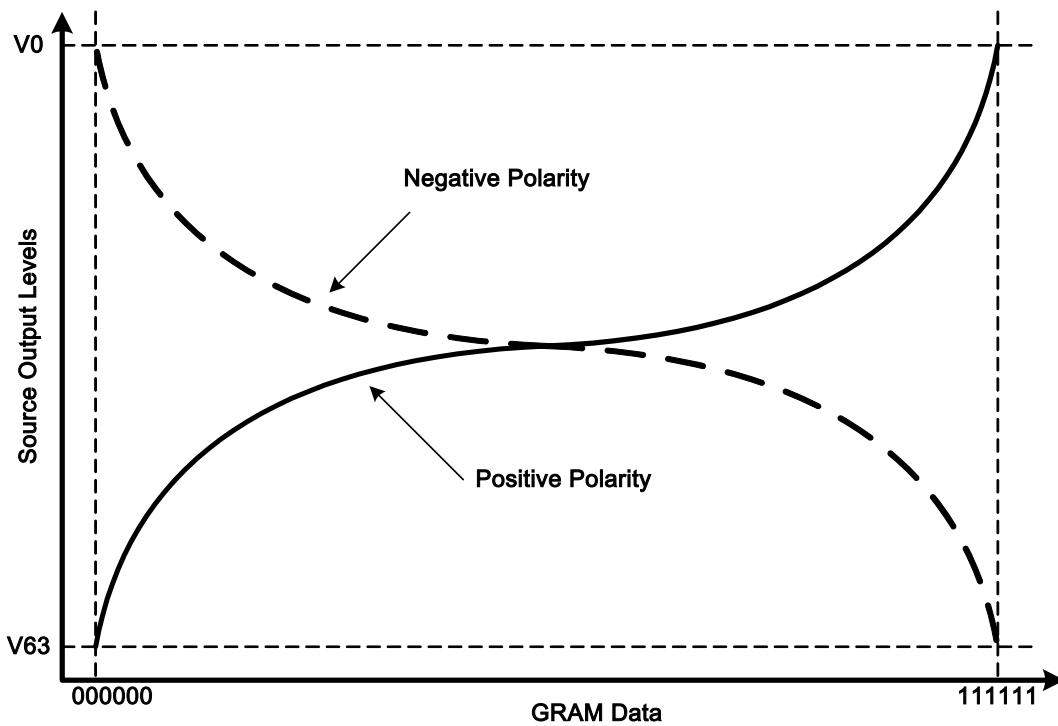

Figure 42 Relationship between GRAM Data and Output Level

13. Application

13.1. Configuration of Power Supply Circuit

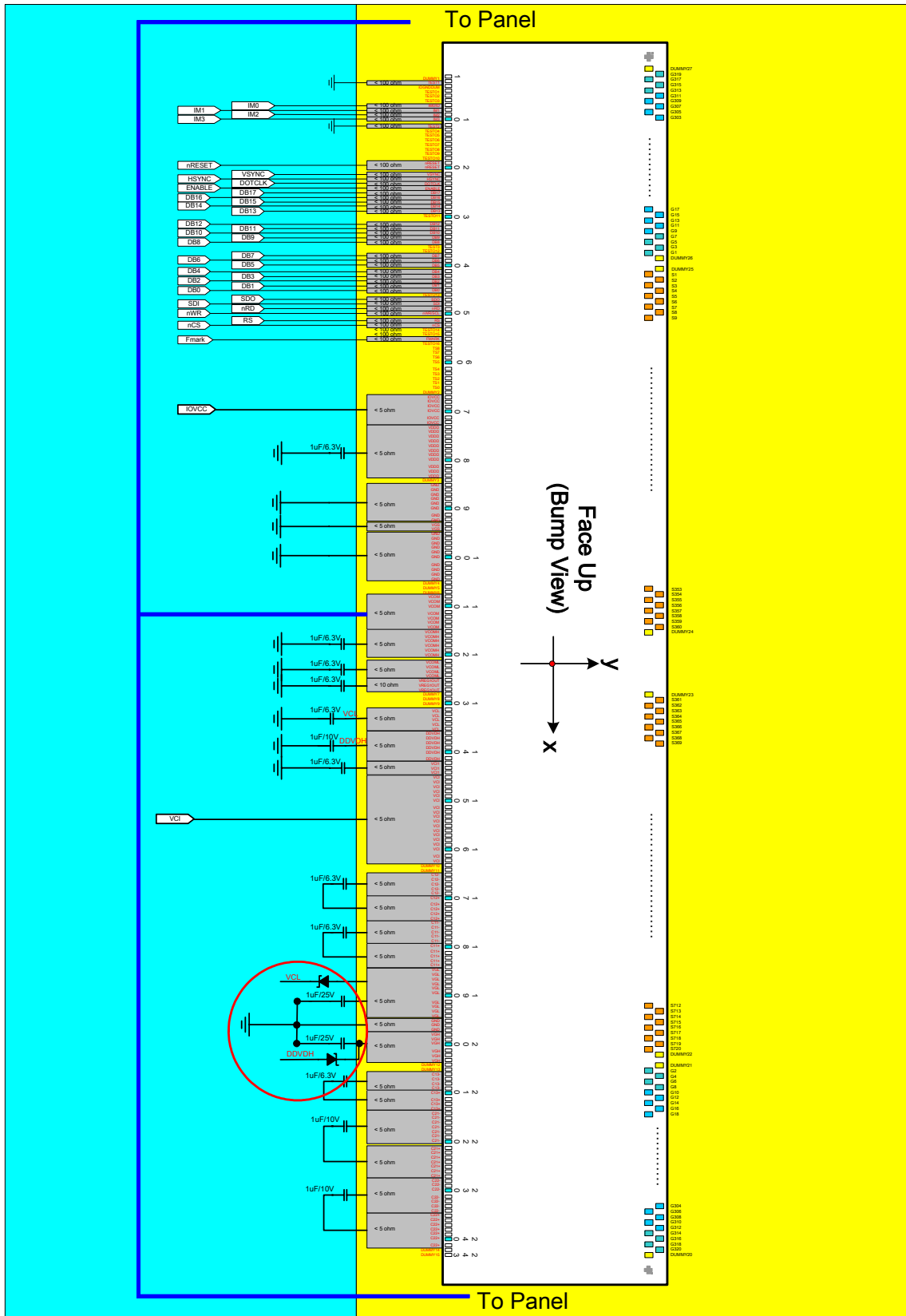

Figure 43 Power Supply Circuit Block

The following table shows specifications of external elements connected to the ILI9325's power supply circuit.

Items	Recommended Specification	Pin connection
Capacity 1 μ F (B characteristics)	6.3V	VREG1OUT, VCI1, VDDD, VCL, VCOMH, VCOML, C11+/-, C12+/-, C13+/-,
	10V	DDVDH, C21+/-, C22+/-
	25V	VGH, VGL
Schottky diode	VF<0.4V/20mA at 25°C, VR \geq30V (Recommended diode: HSC226)	(GND – VGL), (Vci – VGH), (Vci – DDVDH)

13.2. Display ON/OFF Sequence

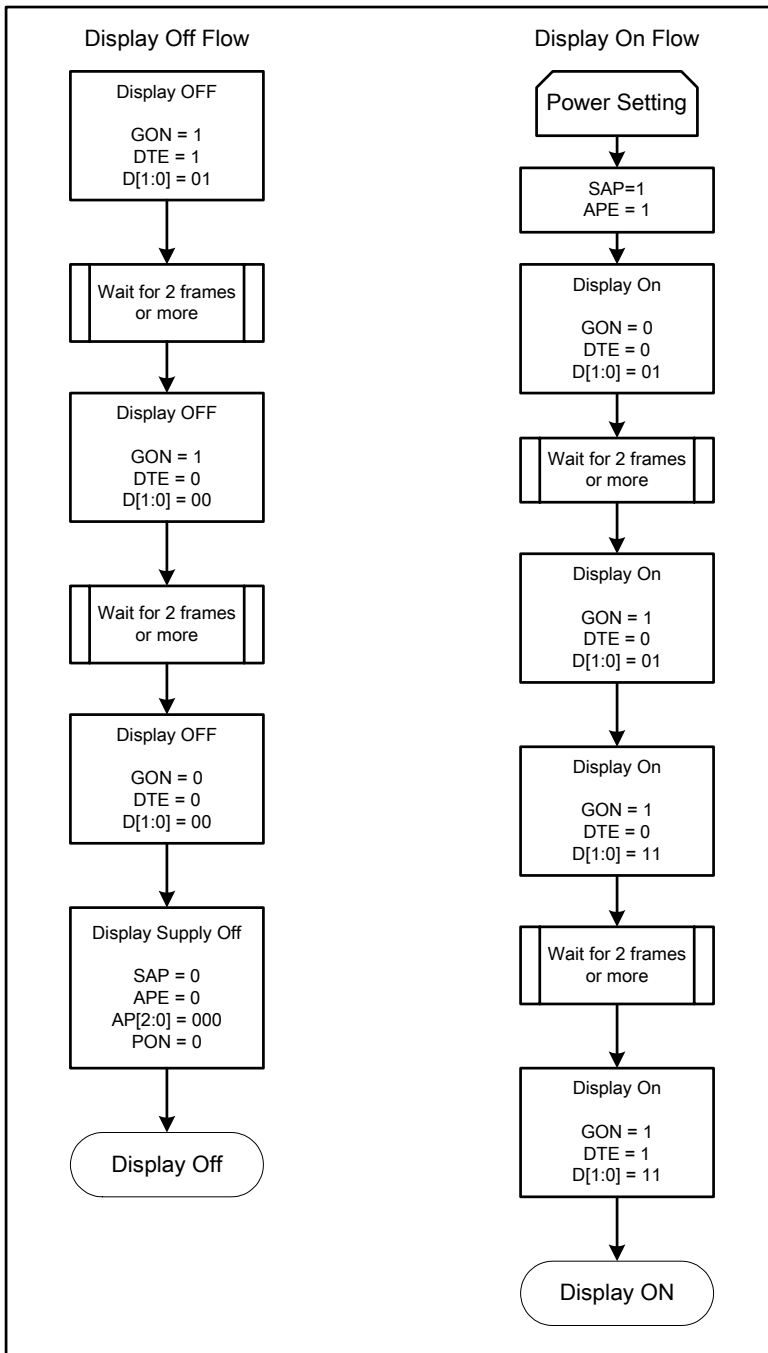

Figure 44 Display On/Off Register Setting Sequence

13.3. Standby and Sleep Mode

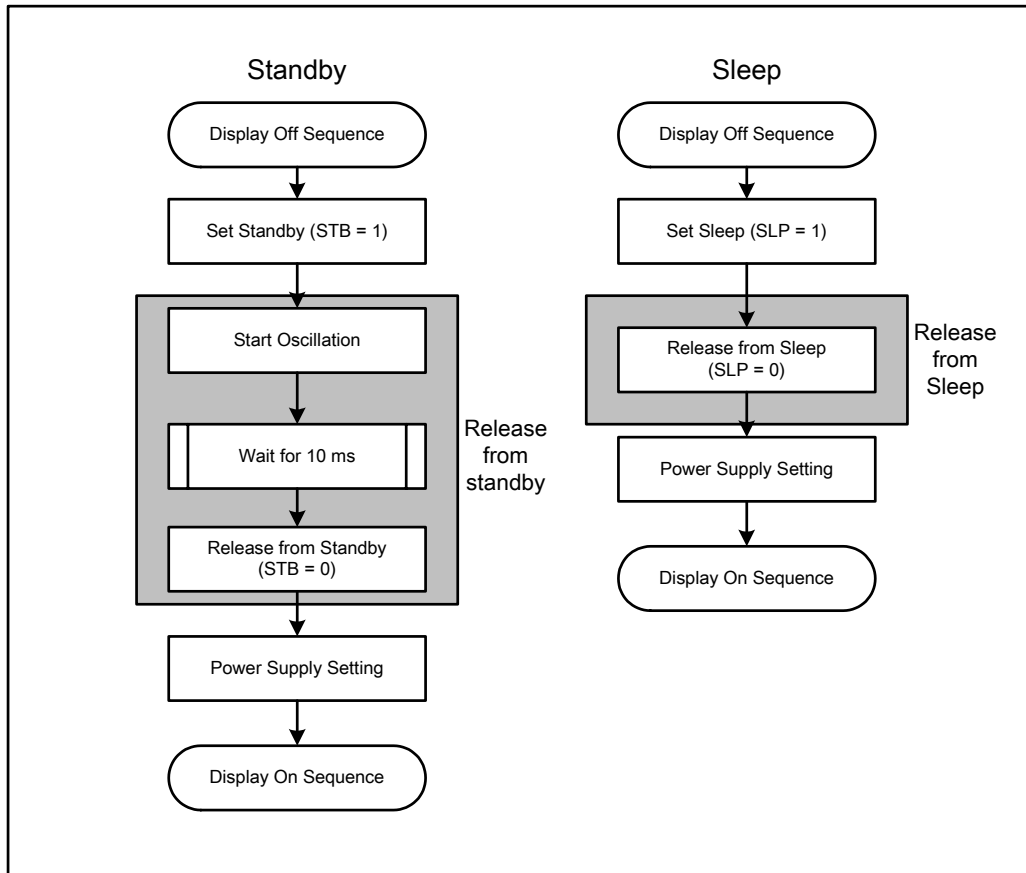

Figure 45 Standby/Sleep Mode Register Setting Sequence

13.4. Power Supply Configuration

When supplying and cutting off power, follow the sequence below. The setting time for oscillators, step-up circuits and operational amplifiers depends on external resistance and capacitance.

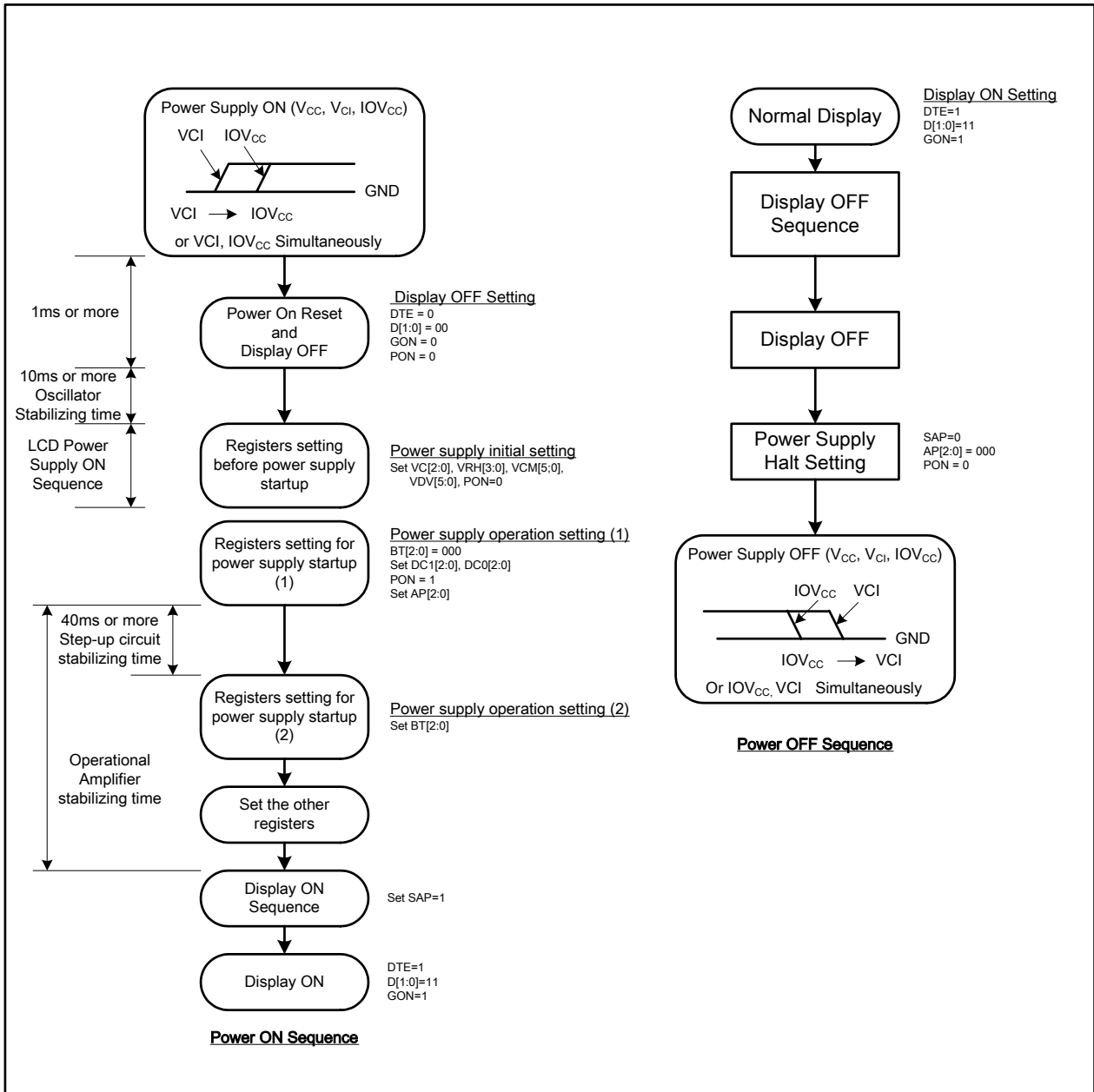

Figure 46 Power Supply ON/OFF Sequence

13.5. Voltage Generation

The pattern diagram for setting the voltages and the waveforms of the voltages of the ILI9325 are as follows.

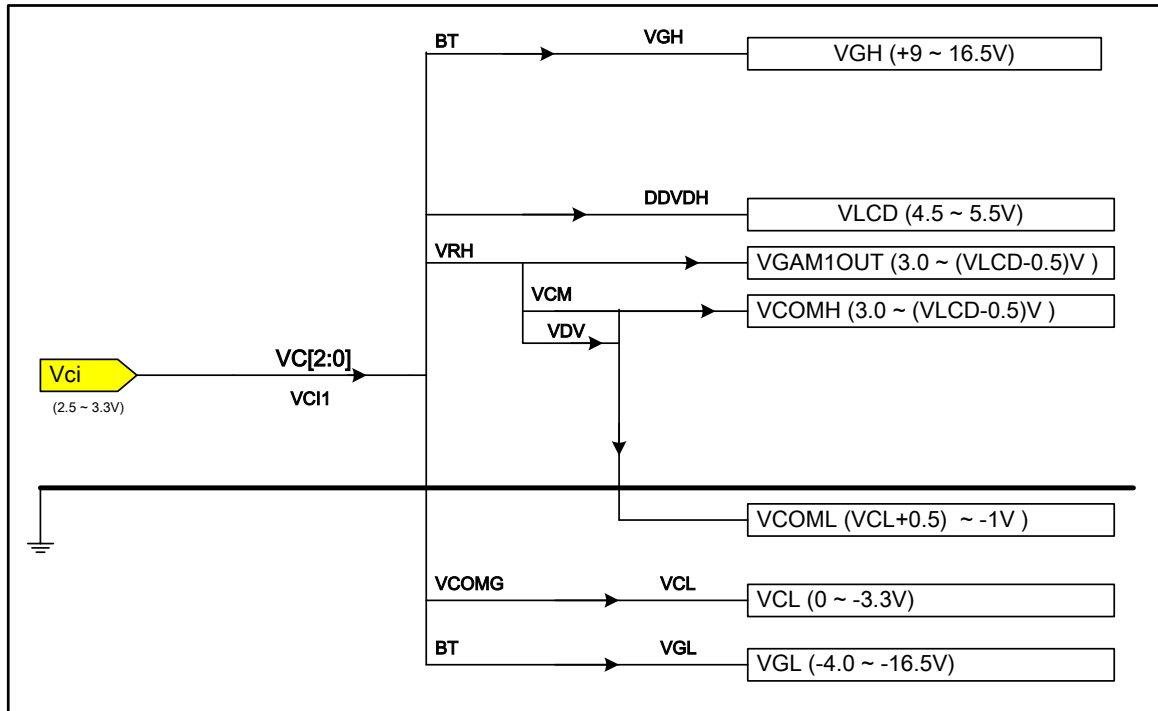

Figure 47 Voltage Configuration Diagram

Note: The DDVDH, VGH, VGL, and VCL output voltage levels are lower than their theoretical levels (ideal voltage levels) due to current consumption at respective outputs. The voltage levels in the following relationships $(DDVDH - VREG1OUT) > 0.5V$, $(VCOML - VCL) > 0.5V$, $(VCOML - VCL) > 0.5V$ are the actual voltage levels. When the alternating cycles of VCOM are set high (e.g. the polarity inverts every line cycle), current consumption is large. In this case, check the voltage before use.

13.6. Applied Voltage to the TFT panel

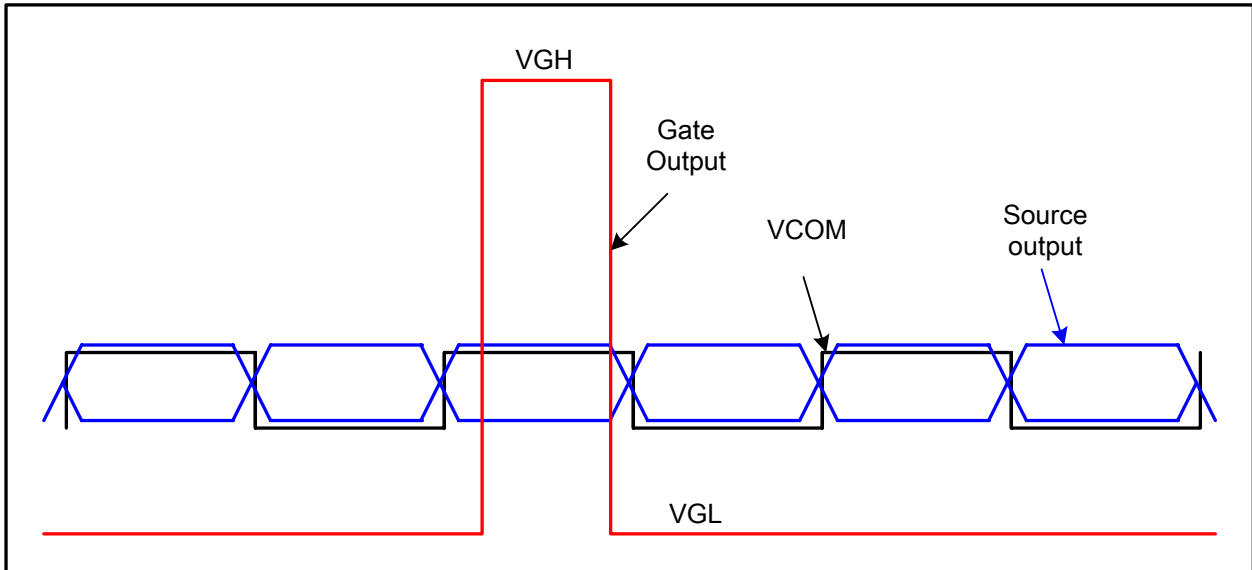

Figure 48 Voltage Output to TFT LCD Panel

13.7. Partial Display Function

The ILI9325 allows selectively driving two partial images on the screen at arbitrary positions set in the screen drive position registers.

The following example shows the setting for partial display function:

Base Image Display Setting	
BASEE	0
NL[5:0]	6'h27
Partial Image 1 Display Setting	
PTDE0	1
PTSA0[8:0]	9'h000
PTEA0[8:0]	9'h00F
PTDP0[8:0]	9'h080
Partial Image 2 Display Setting	
PTDE1	1
PTSA1[8:0]	9'h020
PTEA1[8:0]	9'h02F
PTDP1[8:0]	9'h0C0

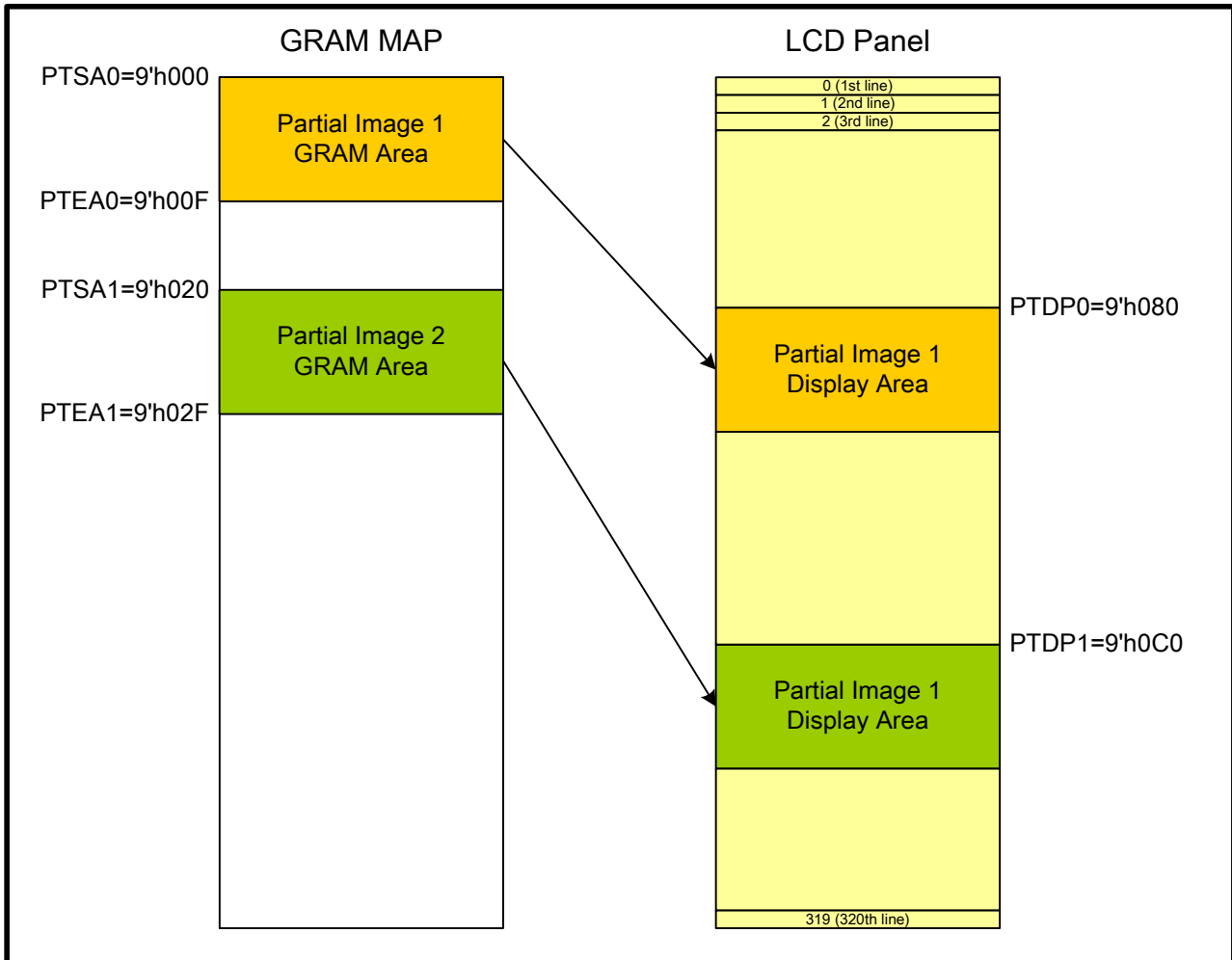

Figure 49 Partial Display Example

13.8. Resizing Function

ILI9325 supports resizing function (x1/2, x1/4), which is performed when writing image data to GRAM. The resizing function is enabled by setting a window address area and the RSZ bit which represents the resizing factor (x1/2, x1/4) of image. The resizing function allows the system to transfer the original-size image data into the GRAM with resized image data.

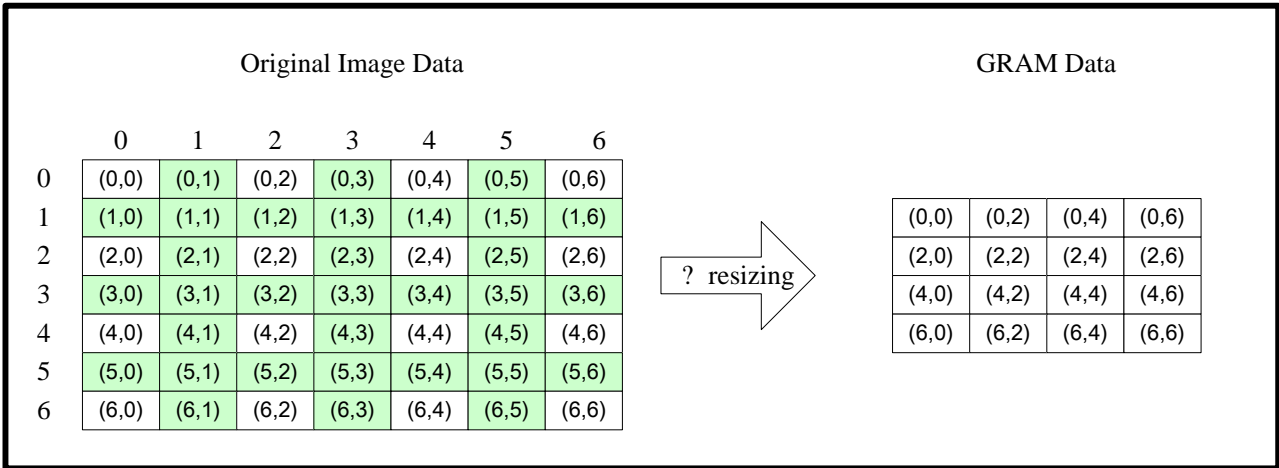

Figure 50 Data transfer in resizing

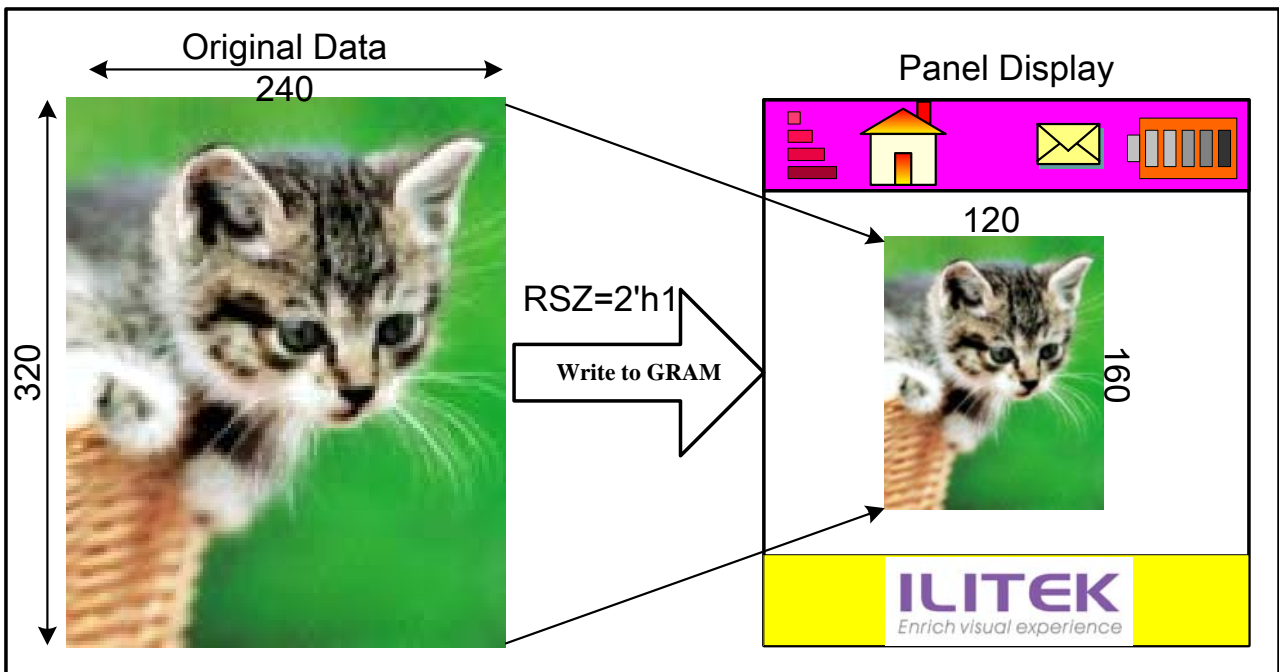
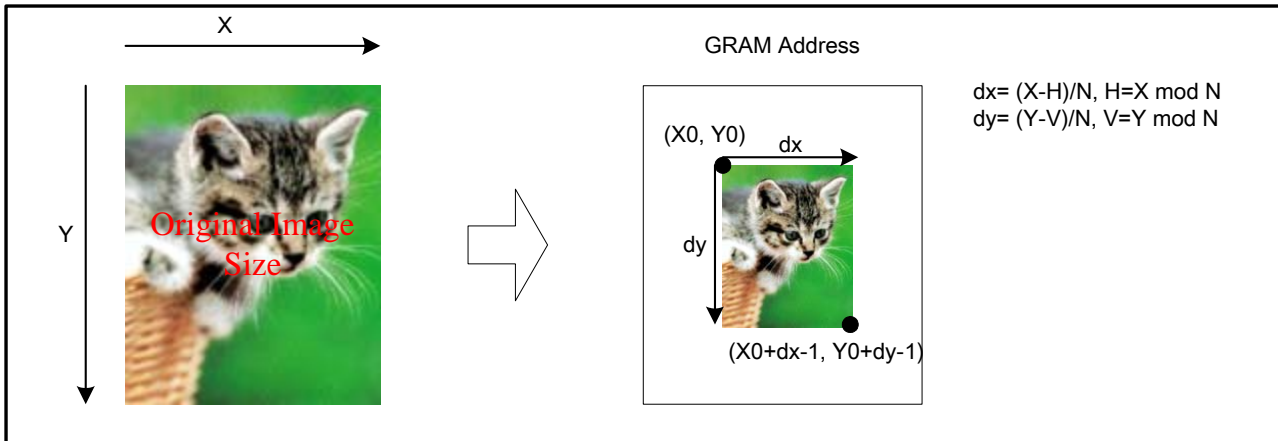

Figure 51 Resizing Example

Original Image Size (X × Y)	Resized Image Resolution	
	1/2 (RSZ=2'h1)	1/4 (RSZ=2'h3)
640 × 480	320 × 240	160 × 120
352 × 288	176 × 144	88 × 72
320 × 240	160 × 120	80 × 60
176 × 144	88 × 72	44 × 36
120 × 160	60 × 80	30 × 40
132 × 132	66 × 66	33 × 33

The RSZ bit sets the resizing factor of an image. When setting a window address area in the internal GRAM, the GRAM window address area must fit the size of resized image. The following example show the resizing setting.



Original image data number in horizontal direction		X
Original image data number in Vertical direction		Y
Resizing Ration		1/N
Resizing Setting	RSZ	N-1
Remainder pixels in horizontal direction	RCH	H
Remainder pixels in vertical direction	RCV	V
GRAM writing start address	AD	(x0, y0)
GRAM window setting	HSA	x0
	HEA	x0+dx-1
	VSA	y0
	VEA	y0+dy-1

14. Electrical Characteristics

14.1. Absolute Maximum Ratings

The absolute maximum rating is listed on following table. When ILI9325 is used out of the absolute maximum ratings, the ILI9325 may be permanently damaged. To use the ILI9325 within the following electrical characteristics limit is strongly recommended for normal operation. If these electrical characteristic conditions are exceeded during normal operation, the ILI9325 will malfunction and cause poor reliability.

Item	Symbol	Unit	Value	Note
Power supply voltage (1)	IOVCC	V	-0.3 ~ + 4.6	1, 2
Power supply voltage (1)	VCI - GND	V	-0.3 ~ + 4.6	1, 4
Power supply voltage (1)	DDVDH - GND	V	-0.3 ~ + 6.0	1, 4
Power supply voltage (1)	GND -VCL	V	-0.3 ~ + 4.6	1
Power supply voltage (1)	DDVDH - VCL	V	-0.3 ~ + 9.0	1, 5
Power supply voltage (1)	VGH - GND	V	-0.3 ~ + 18.5	1, 5
Power supply voltage (1)	GND - VGL	V	-0.3 ~ + 18.5	1, 6
Input voltage	Vt	V	-0.3 ~ VCC+ 0.3	1
Operating temperature	Topr	°C	-40 ~ + 85	8, 9
Storage temperature	Tstg	°C	-55 ~ + 110	8, 9

Notes:

1. GND must be maintained
2. (High) (VCC = VCC) ≥ GND (Low), (High) IOVCC ≥ GND (Low).
3. Make sure (High) VCI ≥ GND (Low).
4. Make sure (High) DDVDH ≥ GND (Low).
5. Make sure (High) DDVDH ≥ VCL (Low).
6. Make sure (High) VGH ≥ GND (Low).
7. Make sure (High) GND ≥ VGL (Low).
8. For die and wafer products, specified up to 85°C.
9. This temperature specifications apply to the TCP package

14.2. DC Characteristics

(VCC = VCI=2.40 ~ 3.0V, IOVCC = 1.65 ~ 3.30V, Ta= -40 ~ 85 °C)

Item	Symbol	Unit	Test Condition	Min.	Typ.	Max.	Note
Input high voltage	V _{IH}	V	IOVCC= 1.8 ~ 3.3V	0.8*IOVCC	-	IOVCC	-
Input low voltage	V _{IL}	V	IOVCC= 1.8 ~ 3.3V	-0.3	-	0.2*IOVCC	-
Output high voltage(1) (DB0-17 Pins)	V _{OH1}	V	IOH = -0.1 mA	0.8*IOVCC	-	-	-
Output low voltage (DB0-17 Pins)	V _{OL1}	V	IOVCC=1.65~3.3V	-	-	0.2*IOVCC	-
I/O leakage current	I _{LI}	μA	Vin = 0 ~ VCC	-0.1	-	0.1	-
Current consumption during normal operation (V _{CC} - GND)	I _{OP}	μA	VCC=2.8V , Ta=25°C , fOSC = 512KHz (Line) GRAM data = 0000h	-	100 (VCC)	-	-
Current consumption during standby mode (V _{CC} - GND)	I _{ST}	μA	VCI=2.8V , Ta=25°C	-	30	50	-
LCD Drive Power Supply Current (DDVDH-GND)	ILCD	mA	VCI=2.8V , VREG1OUT =4.8V DDVDH=5.2V , Frame Rate: 70Hz, line-inversion, Ta=25°C, GRAM data = 0000h,	-	5.0	-	-
LCD Driving Voltage (DDVDH-GND)	DDVDH	V	-	4.5	-	6	-
Dispersion of the Average Output Voltage	V	mV	-	-10	-	10	-

14.3. Reset Timing Characteristics

Reset Timing Characteristics (IOVCC = 1.65 ~ 3.3 V)

Item	Symbol	Unit	Min.	Typ.	Max.
Reset low-level width	t _{RES}	ms	1	-	-
Reset rise time	t _{RES}	μs	-	-	10



14.4. AC Characteristics

14.4.1. i80-System Interface Timing Characteristics

Normal Write Mode (IOVCC = 1.65~3.3V)

Item	Symbol	Unit	Min.	Typ.	Max.	Test Condition
Bus cycle time	Write	t _{CYCW}	ns	100	-	-
	Read	t _{CYCR}	ns	300	-	-
Write low-level pulse width	PW _{LW}	ns	50	-	500	-
Write high-level pulse width	PW _{HW}	ns	50	-	-	-
Read low-level pulse width	PW _{LR}	ns	150	-	-	-
Read high-level pulse width	PW _{HR}	ns	150	-	-	-

The information contained herein is the exclusive property of ILI Technology Corp. and shall not be distributed, reproduced, or disclosed in whole or in part without prior written permission of ILI Technology Corp.

Write / Read rise / fall time		t_{WR}/t_{WRf}	ns	-	-	25
Setup time	Write (RS to nCS, E/nWR)	t_{AS}	ns	10	-	-
	Read (RS to nCS, RW/nRD)			5	-	-
Address hold time		t_{AH}	ns	5	-	-
Write data set up time		t_{DSW}	ns	10	-	-
Write data hold time		t_H	ns	15	-	-
Read data delay time		t_{DDR}	ns	-	-	100
Read data hold time		t_{DHR}	ns	5	-	-

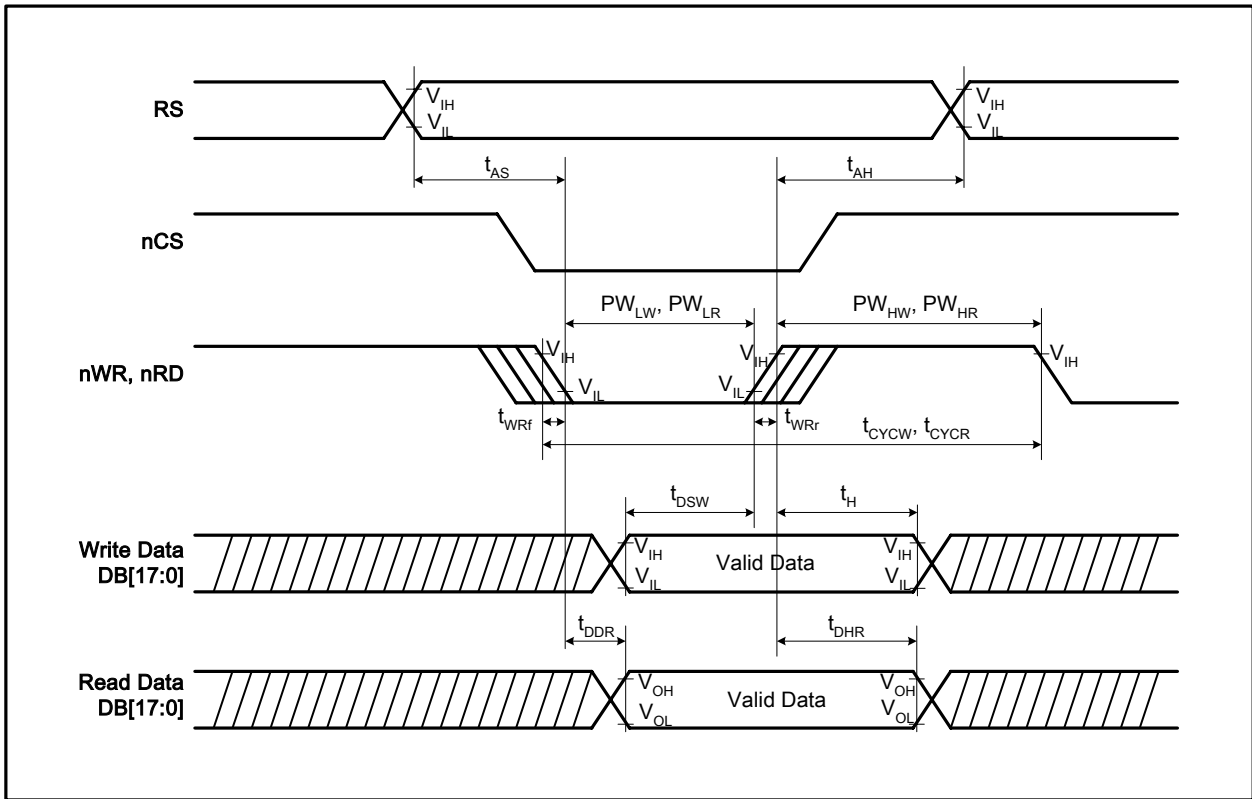

Figure 52 i80-System Bus Timing

14.4.2. Serial Data Transfer Interface Timing Characteristics

(IOVCC= 1.65 ~ 3.3V)

Item	Symbol	Unit	Min.	Typ.	Max.	Test Condition
Serial clock cycle time	Write (received)	t_{SCYC}	μs	100	-	-
	Read (transmitted)	t_{SCYC}	μs	200	-	-
Serial clock high – level pulse width	Write (received)	t_{SCH}	ns	40	-	-
	Read (transmitted)	t_{SCH}	ns	100	-	-
Serial clock low – level pulse width	Write (received)	t_{SCL}	ns	40	-	-
	Read (transmitted)	t_{SCL}	ns	100	-	-
Serial clock rise / fall time	t_{SCr}, t_{SCf}	ns	-	-	5	
Chip select set up time	t_{CSU}	ns	10	-	-	
Chip select hold time	t_{CH}	ns	50	-	-	
Serial input data set up time	t_{SISU}	ns	20	-	-	
Serial input data hold time	t_{SIH}	ns	20	-	-	
Serial output data set up time	t_{SOD}	ns	-	-	100	

The information contained herein is the exclusive property of ILI Technology Corp. and shall not be distributed, reproduced, or disclosed in whole or in part without prior written permission of ILI Technology Corp.

Item	Symbol	Unit	Min.	Typ.	Max.	Test Condition
Serial output data hold time	t_{SOH}	ns	5	-	-	

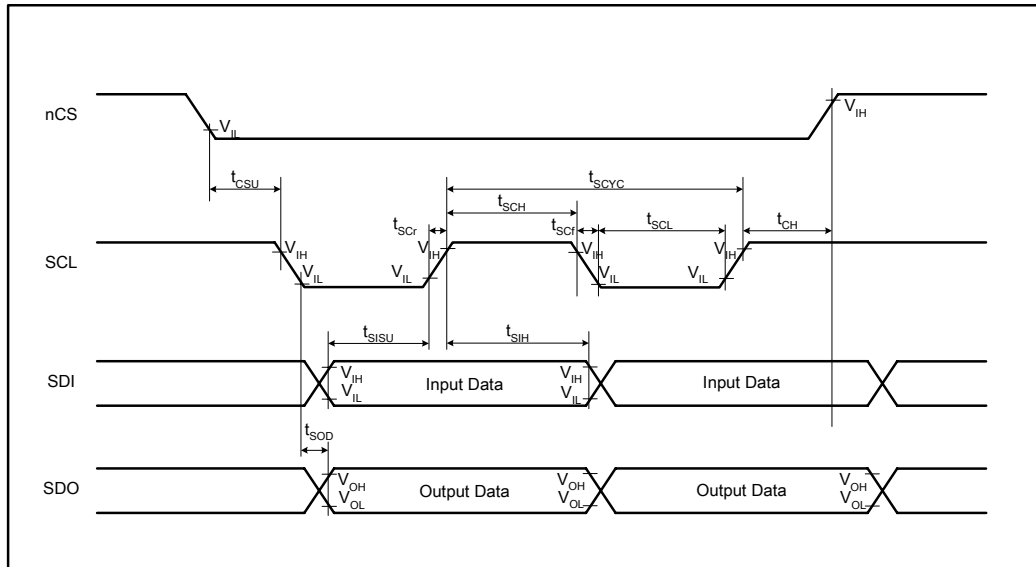

Figure 53 SPI System Bus Timing

14.4.3. RGB Interface Timing Characteristics

18/16-bit Bus RGB Interface Mode (IOVCC = 1.65 ~ 3.3V)

Item	Symbol	Unit	Min.	Typ.	Max.	Test Condition
VSYNC/HSYNC setup time	t_{SYNCS}	ns	0	-	-	-
ENABLE setup time	t_{ENS}	ns	10	-	-	-
ENABLE hold time	t_{ENH}	ns	10	-	-	-
PD Data setup time	t_{PDS}	ns	10	-	-	-
PD Data hold time	t_{PDH}	ns	40	-	-	-
DOTCLK high-level pulse width	PWDH	ns	40	-	-	-
DOTCLK low-level pulse width	PWDL	ns	40	-	-	-
DOTCLK cycle time	t_{CYCD}	ns	100	-	-	-
DOTCLK, VSYNC, HSYNC, rise/fall time	t_{rghr}, t_{rghf}	ns	-	-	25	-

6-bit Bus RGB Interface Mode (IOVCC = 1.65 ~ 3.3V)

Item	Symbol	Unit	Min.	Typ.	Max.	Test Condition
VSYNC/HSYNC setup time	t_{SYNCS}	ns	0	-	-	-
ENABLE setup time	t_{ENS}	ns	10	-	-	-
ENABLE hold time	t_{ENH}	ns	10	-	-	-
PD Data setup time	t_{PDS}	ns	10	-	-	-
PD Data hold time	t_{PDH}	ns	30	-	-	-
DOTCLK high-level pulse width	PWDH	ns	30	-	-	-
DOTCLK low-level pulse width	PWDL	ns	30	-	-	-
DOTCLK cycle time	t_{CYCD}	ns	80	-	-	-
DOTCLK, VSYNC, HSYNC, rise/fall time	t_{rghr}, t_{rghf}	ns	-	-	25	-

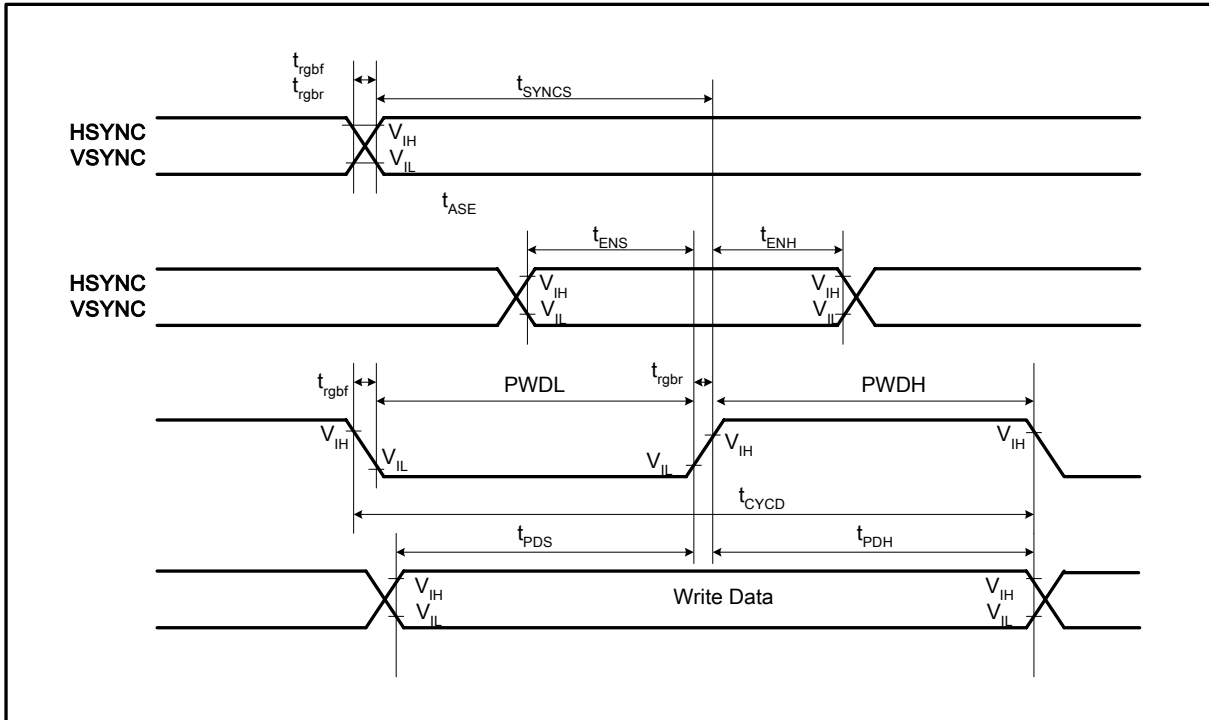

Figure54 RGB Interface Timing

15. Revision History

Version No.	Date	Page	Description
V0.28	2007/07/05	96	Modify the FPC circuit
V0.29	2007/07/12	15	Modify the alignment mark pattern
V0.30	2007/09/07	55	Modify the frame rate setting of R2Bh register
V0.31	2007/10/29	57	Add the high speed write function
V0.32	2007/11/02	71、 72	Modify Frame rate value by register setting
V0.33	2007/11/08	105	Delete Output Voltage deviation item